

REVISION RECORD				
REV	ECN	DESCRIPTION	DRFT	DATE

NOTES1:  
 UL Standard  
 1.Rated voltage/current : 300V / 20A  
 2.Torque value : M4 , 10.53Lb.in  
 3.Wire range : 20~12AWG

IEC Standard  
 1.Rated voltage/current : 250V / 32A  
 2.Torque value : M4 , 1.2N·m  
 3.Wire range : 0.75~4mm<sup>2</sup>

NOTES2:  
 1.Dimension shall be interpreted per ASME Y14.5-2009  
 2. Poles :01P  
 3.Stripping length : 8~10mm  
 4.Withstanding voltage : AC2000V/1Min  
 5.Operating temperature:-40°C~+105°C  
 6.Undimensioned tolerances:

Pitch range in mm		Nominal dimension range in mm						-	∩	∇
TO	Over	Over	Over	Over	Over	Over		0.1/10		
6	6 TO 10	10 TO 24	30 TO 60	60 TO 100	100 TO 150	150		<		
±0.15	±0.20	±0.30	±0.30	±0.50	±0.70	±1.00	±1.30		±2'	

6.RoHS Compliance

H  
G  
F  
E  
D  
C  
B  
A

H  
G  
F  
E  
D  
C  
B  
A

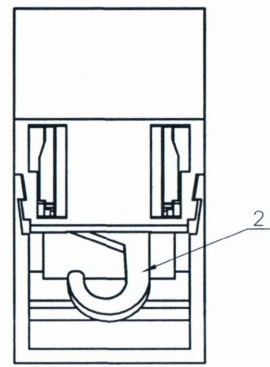
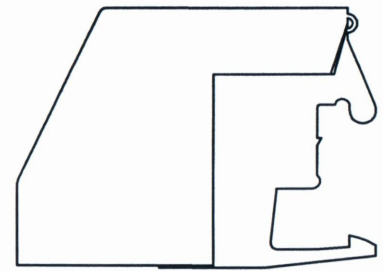
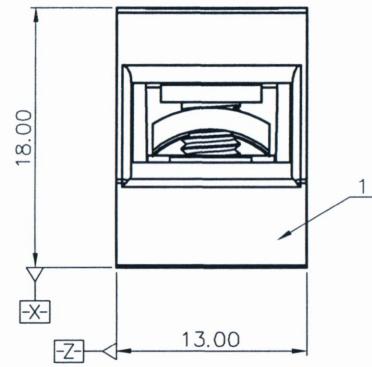
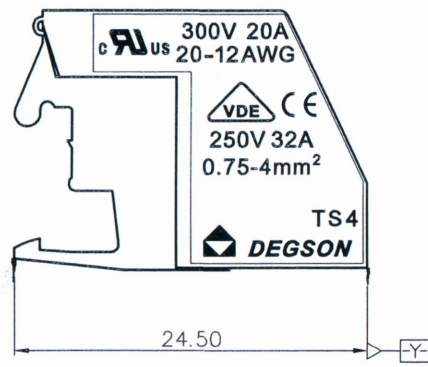

TS4 - 01P - 1C - 11A (H)  
 (Series No.) (Poles) (Single Pitch) (Color):C.(Yellow and green)  
 (RoHS)  
 11A-(Customer Request)

仅供参考图  
 日期: 3 30-18

ITEM	NAME OF PART	MATERIAL	NOTES
3	Screw	Steel	M4/Zn Plated
2	Pin header	Copper alloy	Sn Plated
1	Housing	PA66	UL94V-0

DETACHED LISTS	PART NO.: /	宁波高松电子有限公司 NINGBO DEGSON ELECTRICAL CO., LTD			
	APPD: <i>Adrian 2018.3.30</i>	NAME: TS4-01P-1C-11A(H)			
	CHKD:	DRFT: LJH 2018.03.30			
	TITLE: CUSTOMER DRAWING		REV	D0-1	
	DRAWING NO.: TS4-C11		SHEET	1/1	
THIRD ANGLE PROJECTION MM (INCH)		DO NOT SCALE DRAWING	SCALE	1:1	

A