

SCHMID-M



SVRB_LD-30WR2

30W, WIDE INPUT, ISOLATED & REGULATED SINGLE OUTPUT DC-DC CONVERTER

PART NUMBER SYSTEM

SVRB2405LD-30WR2

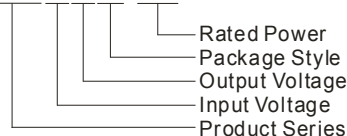

Rated Power
Package Style
Output Voltage
Input Voltage
Product Series

FEATURES

- Efficiency up to 89%
- 2:1 wide input voltage range
- 1.5KVDC isolation
- Six-sided metal shield
- Short circuit protection (automatic recovery)
- Operating temperature range: -40°C ~ +85°C
- Industry standard pinout
- Low ripple and noise
- Meet CISPR22/EN55022 CLASS A

APPLICATION

The SVRB_LD-30WR2 series offer 30W of output, with 2:1 wide input voltage of 18-36VDC, 36-75VDC and features 1500VDC isolation, over current and short-circuit protection etc, as well as six-sided metal shielding. All models are particularly suited to industrial control, electric power, instrumentation, tele-communications etc.

SELECTION GUIDE

Model	Input Voltage (VDC)		Output Voltage (VDC)	Output Current (mA)		Input Current (mA)(typ.)		reflection ripple Current (mA,typ.)	Max. Capacitor Load (max,µF)	Efficiency (%. typ.) @ Max. load
	Nominal (Range)	Max*		Max.	Min.	@ Max.load	@ No load			
SVRB2403LD-30WR2	24 (18-36)	40	3.3	6000	600	960	120	48	6800	87
SVRB2405LD-30WR2			5	6000	600	1460	120	73	6800	88
SVRB2412LD-30WR2			12	2500	250	1440	20	72	680	88
SVRB2415LD-30WR2			15	2000	200	1440	20	72	680	89
SVRB2424LD-30WR2			24	1250	125	1440	20	72	470	89
SVRB4803LD-30WR2	48 (36-75)	80	3.3	6000	600	500	80	25	6800	87
SVRB4805LD-30WR2			5	6000	600	730	80	36.5	6800	88
SVRB4812LD-30WR2			12	2500	250	720	20	36	680	89
SVRB4815LD-30WR2			15	2000	200	720	20	36	680	89

Note:* Input voltage can't exceed this value, or will cause the permanent damage.

INPUT SPECIFICATIONS

Item	Test conditions	Min.	Typ.	Max.	Unit
Input Surge Voltage (1000 ms)	24VDC Input Models	-0.7	--	50	VDC
	48VDC Input Models	-0.7	--	100	
Start-up Voltage	24VDC Input Models	--	17.8	18	
	48VDC Input Models	--	35.8	36	
Under Voltage Shutdown	24VDC Input Models	16	--	--	
	48VDC Input Models	32	--	--	
Start-up time	Nominal input & constant resistance load	--	10	--	ms
Ctrl*	Models ON	Ctrl open or connect TTL high level (3-40VDC)			
	Models OFF	Ctrl connect GND or low level (0-1.2VDC)			
	Input current at shutdown	--	1	--	mA
Input filter		π Filter			

*The CTRL control pin voltage is refer to GND.

OUTPUT SPECIFICATIONS

Item	Test conditions	Min.	Typ.	Max.	Unit
Output power		3	--	30	W
Output voltage accuracy	Refer to recommended circuit	--	±1	±3	%
Line voltage regulation	Input voltage from low to high at 100% load	--	±0.2	±0.5	
Load regulation	From 10% to 100% load Nominal input	--	±0.5	±1	

Transient recovery time	25% load step change		--	300	500	μs
Transient Response Deviation			--	±3	±5	%
Temperature drift	100% load		--	±0.02	--	%/°C
Ripple & noise *	20MHz bandwidth	24VDC output	--	75	200	mVp-p
		Other output	--	50	120	
Output voltage range (Trim)			--	± 10%Vo	--	VDC
Over voltage protection	Full input voltage	3.3VDC output	--	3.9	--	
		5VDC output	--	6.2	--	
		12VDC output	--	15	--	
		15VDC output	--	18	--	
24VDC output	--	28	--			
Over current protection	Full input voltage		120	130	150	%
Short circuit protection			Hiccup, automatic recovery			
Note: *Ripple and noise tested by "parallel cable" method. See detailed operation instructions at Testing of Power Converter section, application notes.						

COMMON SPECIFICATIONS

Item	Test conditions	Min.	Typ.	Max.	Unit
Isolation voltage	Tested for 1 minute and leakage current less than 1 mA	1500	--	--	VDC
Isolation resistance	Test at 500VDC	1000	--	--	MΩ
Isolation capacitance	input / output, 100KHz/0.1V	--	2000	--	pF
Switching frequency		--	300	--	KHz
MTBF	MIL-HDBK-217F@25°C	1000	--	--	K hours
Safety approvals		UL/EN60950(Pending)			
Case material		Aluminum Alloy			
Weight		--	30	--	g

ENVIRONMENTAL SPECIFICATIONS

Item	Test conditions	Min.	Typ.	Max.	Unit
Storage humidity	Non condensing	5	--	95	%
Operating temperature	See Temperature Derating Curve	-40	--	85	°C
Storage temperature		-55	--	125	
The Max. Case Temperature	Operating Temperature curve range	--	--	105	
Soldering temperature	1.5mm from case for 10 seconds	--	--	300	
Cooling		Free Air Convection			
Shake		10-55Hz, 10G, 30 Min. along X, Y and Z			

EMC SPECIFICATIONS

EMI	CE	CISPR22/EN55022	CLASS A (Without External Circuit) / CLASS B (External Circuit Refer to Figure1-②)		
	RE	CISPR22/EN55022	CLASS A (Without External Circuit) / CLASS B (External Circuit Refer to Figure1-②)		
EMS	ESD	IEC/EN61000-4-2	Air ±8KV / Contact ±4KV perf. Criteria B		
	RS	IEC/EN61000-4-3	10V/m perf. Criteria A		
	EFT	IEC/EN61000-4-4	±2KV perf. Criteria B (External Circuit Refer to Figure1-①)		
	Surge	IEC/EN61000-4-5	±2KV perf. Criteria B (External Circuit Refer to Figure1-①)		
	CS	IEC/EN61000-4-6	10 Vr.m.s perf. Criteria B		
	Voltage dips, short and interruptions immunity	IEC/EN61000-4-29	0%-70% perf. Criteria B		

EMC RECOMMENDED CIRCUIT

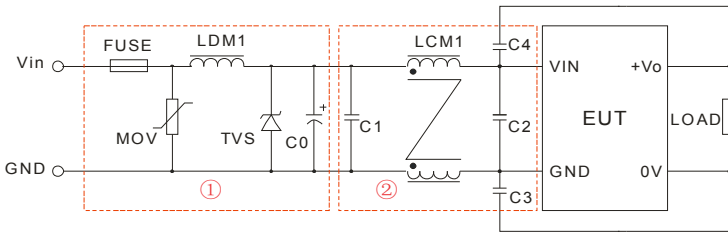

(Figure 1)

Note: In Figure 1, part ① is EMS Recommended external circuit, part ② is EMI recommended external circuit. Choose according to requirements.

Recommended external circuit parameters			
EMS	Model	SVRB24 LD-30WR2	SVRB48 LD-30WR2
	FUSE	Choose according to practical input current	
	MOV	10D560K	10D101K
	LDM1	56μH	56μH
	TVS	SMCJ48A	SMCJ90A
EMI	C0	120μF/50V	120μF/100V
	C1, C2	475K/50V	225K/100V
	LCM1	TS7 T13*7*5 1mH	TS7 T13*7*5 1mH
	C3, C4	102K/2KV	102K/2KV

EMC RECOMMENDED CIRCUIT PCB LAYOUT

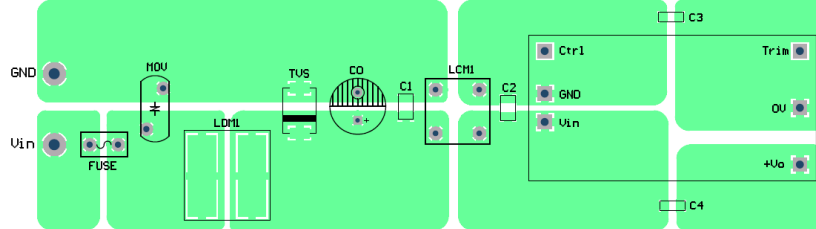

(Figure 2)

PRODUCT TYPICAL CURVE

Temperature derating curve

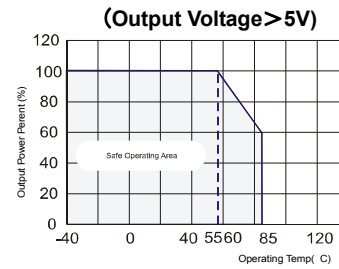
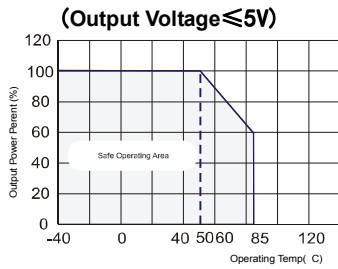

Efficiency VS Input Voltage curve

(Full Load) — SVRB2415LD-30WR2

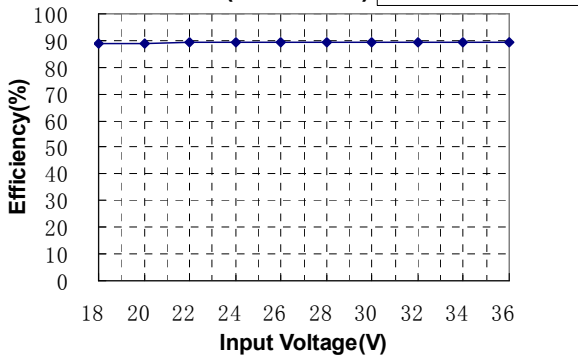

Efficiency VS Output Load curve

(Vin = Vin-nominal) — SVRB2415LD-30WR2

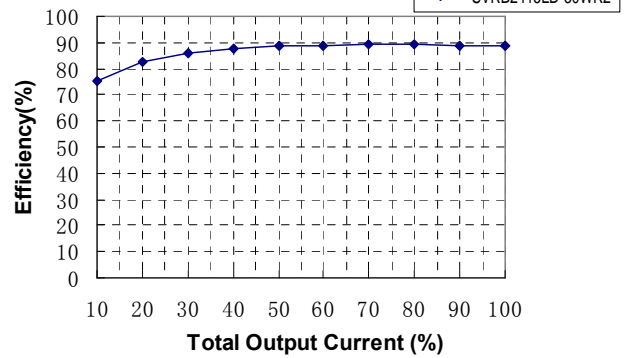

OUTLINE DIMENSIONS, RECOMMENDED FOOTPRINT & PACKAGING

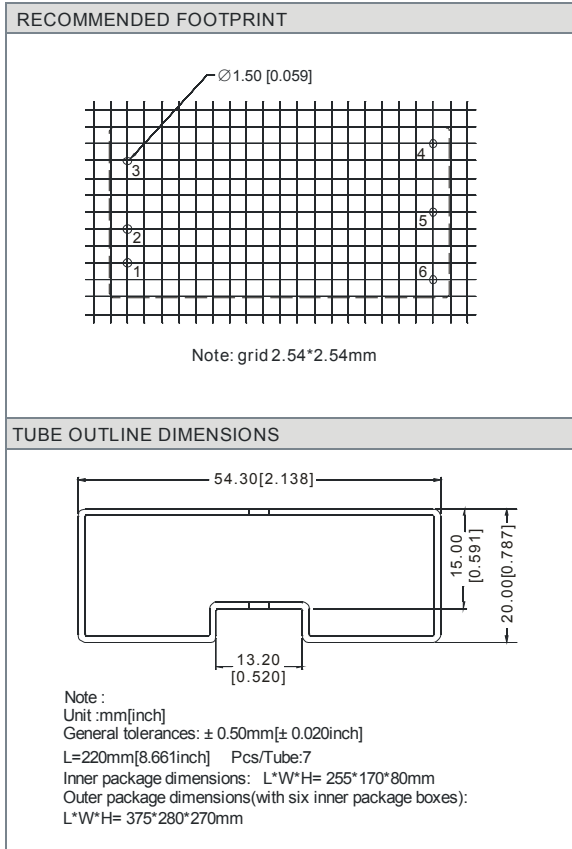
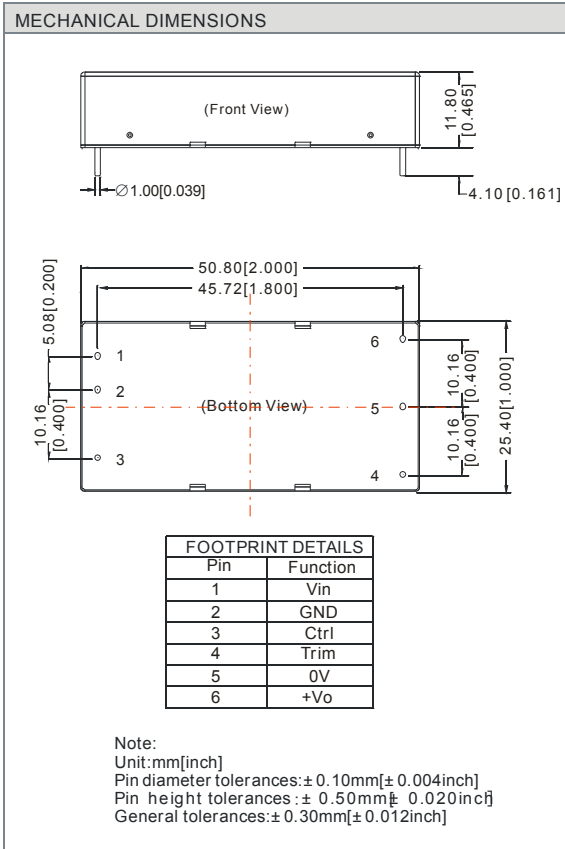

TEST CONFIGURATIONS

Input Reflected-Ripple Current Test Setup

Input reflected-ripple current is measured with an inductor Lin and Capacitor Cin to simulate source impedance.

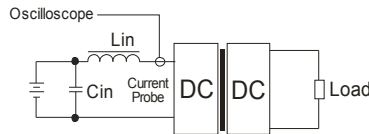

Lin(4.7µH) Cin(220µF, ESR < 1.0Ω at 100 KHz)

TRIM APPLICATION & TRIM RESISTANCE

Application circuit for TRIM (Part in broken line is the interior of models)

Formula for resistance of Trim

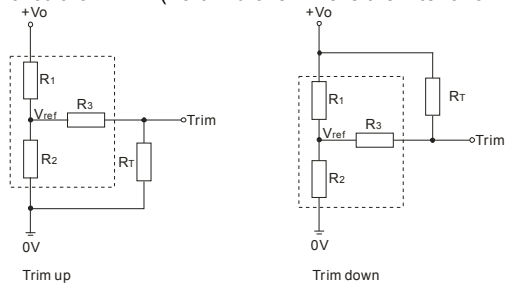

$$\text{up: } R_T = \frac{aR_2}{R_2 - a} - R_3 \quad a = \frac{V_{ref}}{V_o' - V_{ref}} \cdot R_1$$

$$\text{down: } R_T = \frac{aR_1}{R_1 - a} - R_3 \quad a = \frac{V_o' - V_{ref}}{V_{ref}} \cdot R_2$$

Note: Value for R1, R2, R3, and Vref refer to the above table 1.

R_T: Resistance of Trim

a: User-defined parameter, no actual meanings.

Vo': The trim up/down voltage.

(TABLE 1)

Parameter \ Vo	3.3(VDC)	5(VDC)	12(VDC)	15(VDC)	24(VDC)
R1(KΩ)	4.801	2.883	10.971	14.497	24.872
R2(KΩ)	2.863	2.864	2.864	2.864	2.863
R3(KΩ)	15	10	17.8	17.8	20
Vref(V)	1.24	2.5	2.5	2.5	2.5

DESIGN CONSIDERATIONS

1) Requirement on output load

To ensure this module can operate efficiently and reliably, During operation, the minimum output load **could not be less than 10% of the full load**. If the actual output power is very small, please connect a resistor with proper resistance at the output end in parallel to increase the load.

2) Recommended circuit

All the SVRB_LD-30WR2 series have been tested according to the following recommended testing circuit before leaving factory. This series should be tested under load. Never be tested under no load (see Figure 3).

If you want to further decrease the output ripple, you can increase capacitance properly or choose capacitors with low ESR. However, the capacitance can't exceed the maximum capacitor load in the list (Table 2).

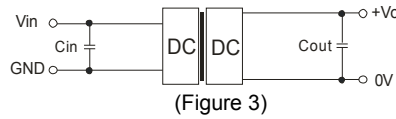

(Figure 3)
EXTERNAL CAPACITOR TABLE (TABLE 2)

Capacitance Output Voltage	Cout(μF)	Cin(μF)
3.3V、5V	220	100
12V、15V	100	
24V	47	

3) Cannot use in parallel and hot swap

Note:

1. Min. load shouldn't be less than 10%, otherwise ripple maybe increase dramatically. Operation under minimum load will not damage the converter, however, they may not meet all specification listed.
2. Max. Capacitive Load tested at input voltage range and full load.
3. All specifications measured at Ta=25°C, humidity<75%, nominal input voltage and rated output load unless otherwise specified.
4. In this datasheet, all the test methods of indications are based on our corporate standards.
5. All characteristics are for listed model only, non-standard models may perform differently, please contact our technical staff for more detail.
6. Contact us for your specific requirement.
7. Specifications subject to change without prior notice.