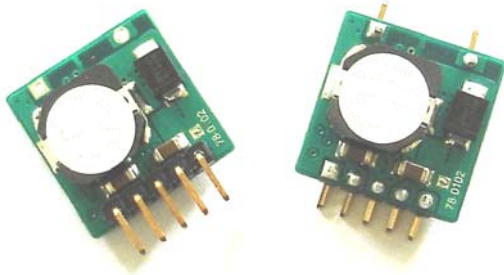

SMQ7862

**Compact, 3~5.5V input, 2A/10W output, Boost DC-DC Converter**

## Applications

- Industry Control
- Audio Video Devices
- Data Acquisition Equipment

## Features

- Wide Operating Voltage: 3V ~ 5.5V
- Output Voltage: 5V ~ 18V
- Output Current Up to 2A
- Output Power Up to 12W
- Low output voltage ripple
- Minimal space on PCB:
  - ◆ SIP PIN out
    - 17.78 mm x 17.78 mm x 6.7 mm or
    - 0.7 in x 0.7 in x 0.26 in
  - ◆ SMT PIN out
    - 17.78 mm x 17.78 mm x 8.8 mm or
    - 0.7 in x 0.7 in x 0.34 in
- No derating to +55°C, natural convection
- UL/IEC/EN60950 compliant
- RoHS Compliant

## Description

The SMQ7862 Series Power Modules are non-isolated dc-dc converters that operate over a wide input voltage range of 3Vdc to 5.5Vdc and provide a precisely (2%) regulated dc output. Such a module is suitable to application with 3.3V or 5V power supply bus to generate 5V, 12V, 15V, and 18V etc bias supply. The modules have a maximum output current rating of 2A at a typical full-load efficiency over 90%. Standard features include remote on/off with negative logic and output voltage adjustment, over-current protection, over-temperature protection.

SMQ7862 series can load 2A/10W in a very small size. This improves PCB layout and system integration capability.

\*\*\*\*\* **Typical Application Circuit** \*\*\*\*\*

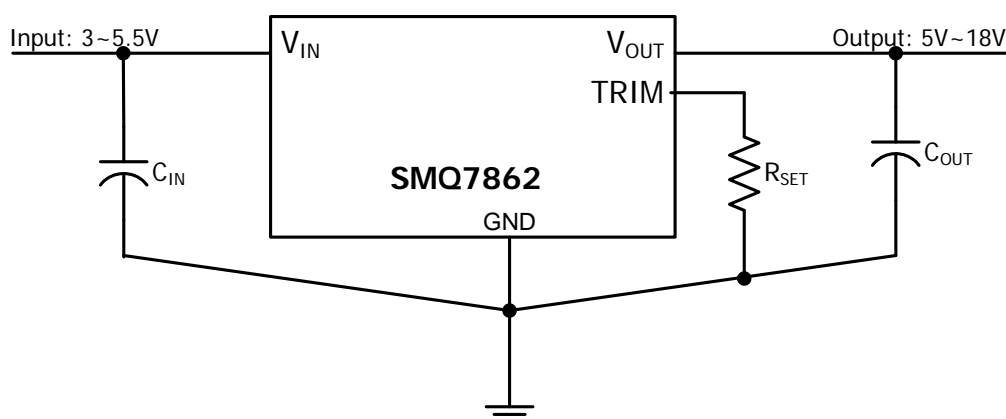

# SMQ7862

## Performance Specifications (at TA=+25°C)

Model	Input $V_{IN}$ Range (V)	Output				Efficiency (%)
		$I_{OUT}$ (A)	Trim Range (V)	Regulation		
				Line (%)	Load (%)	
SMQ7862T050	3~5.5	2	10%	1	2	90
SMQ7862S050				1	2	
SMQ7862T120		1		1	2	91
SMQ7862S120				1	2	
SMQ7862T150		0.6		1	2	TBD
SMQ7862S150				1	2	
SMQ7862T180		0.5		1	2	TBD
SMQ7862S180				1	2	

## Mechanical Specifications

SMQ7862T- Dimensions are in inches (mm)

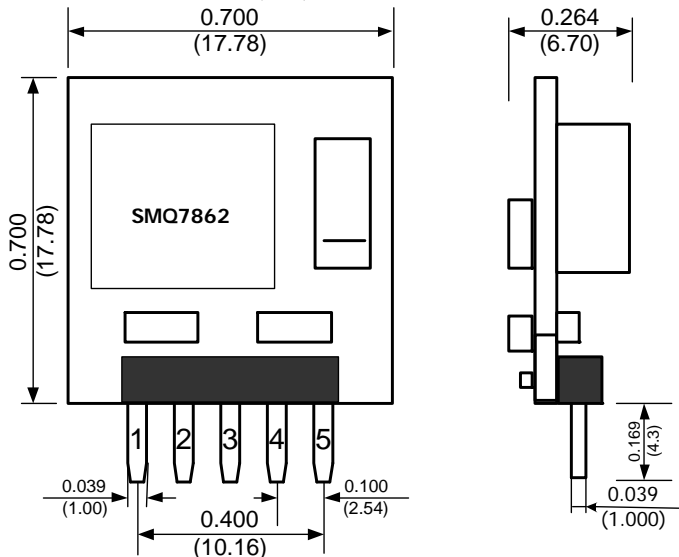

PIN	DESCRIPTION
1	No Connect
2	$V_{in}$
3	GND
4	$V_{out}$
5	$T_{rim}$

SMQ7862S- Dimensions are in inches (mm)

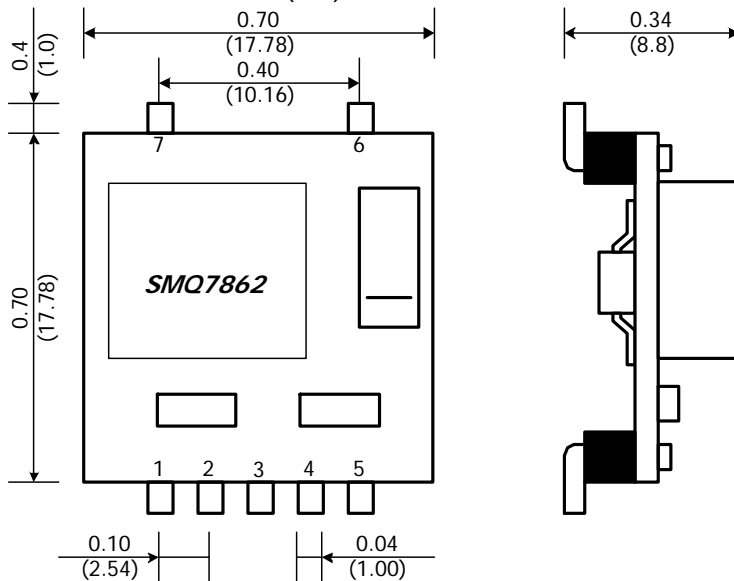

PIN	DESCRIPTION
1	No Connect
2	$V_{in}$
3	GND
4	$V_{out}$
5	$T_{rim}$
6	No Connect
7	No Connect

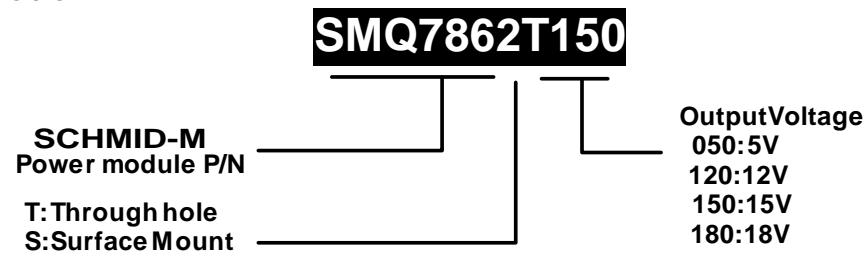
**Ordering Information**

**SMQ7862****Absolute Maximum Ratings**

Note: These are stress ratings. Exposure of devices to any of these conditions may adversely affect long-term reliability. Proper operation under conditions other than those listed in the Performance Specifications Table is not implied.

Parameter	Symbol	Min	Max	Unit
Input Voltage	$V_{IN}$	-0.3	6	V
Storage Temperature	$T_{STG}$	-40	125	°C

**SMQ7862T/S050 Electrical Specifications** ( $T_A = +25^\circ\text{C}$ )

Parameter	Condition	Symbol	Min	Typ	Max	Unit
Input Voltage Range		$V_{IN}$	3		5.5	V
Output Current	$V_{O.set} = 5\text{V}$	$I_o$			2.4	A
Output Voltage Set point	100% load	$\Delta V_o$	-2		+2	%
Temperature Regulation	$T_A = T_{A.MIN}$ To $T_{A.MAX}$	-		0.2		% $V_{O.SET}$
Output Trim Range				5		V
Line Regulation				1%		
Load Regulation				1%		
Output Ripple and Noise Voltage	See Typical Characteristic					
Transient Response						

**SMQ7862T/S120 Electrical Specifications** ( $T_A = +25^\circ\text{C}$ )

Parameter	Condition	Symbol	Min	Typ	Max	Unit
Input Voltage Range		$V_{IN}$	3		5.5	V
Output Current	$V_{O.set} = 12\text{V}$	$I_o$			1	A
Output Voltage Set point	100% load	$\Delta V_o$	-2		+2	%
Temperature Regulation	$T_A = T_{A.MIN}$ To $T_{A.MAX}$	-		0.2		% $V_{O.SET}$
Output Trim Range				12		V
Line Regulation				1%		
Load Regulation				1%		
Output Ripple and Noise Voltage	See Typical Characteristic					
Transient Response						

Test Configurations

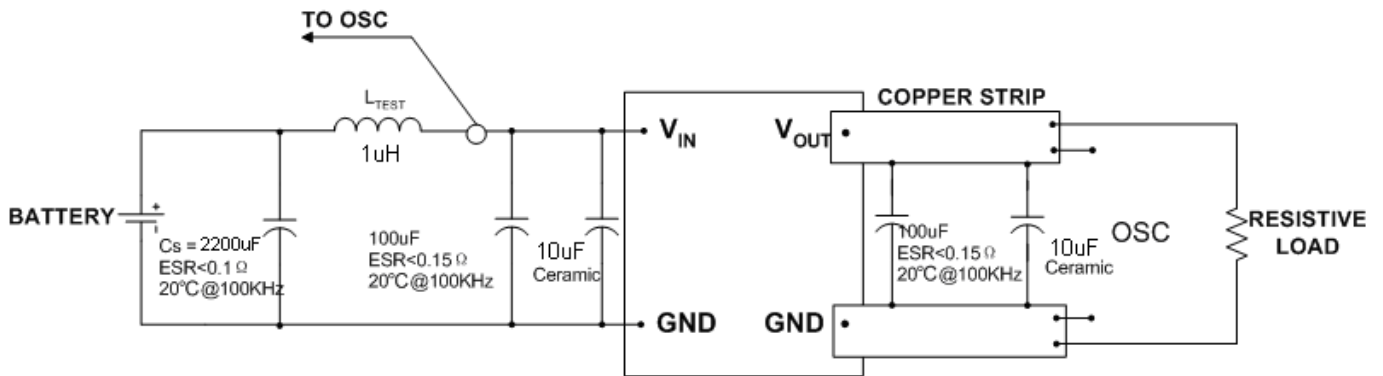

Test setup for input noise, output noise and ripple

Note:

Output noise is measured with 0.1  $\mu$  F ceramic capacitor connected at the output. OSC measurement should be made using a BNC socket. Position the load between 50mm and 75mm (2in. and 3in) from the tested module.

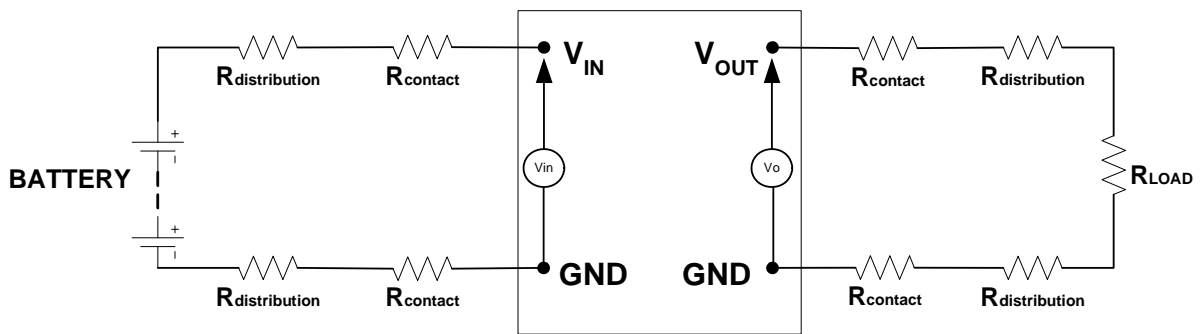

Test setup for efficiency

Note:

All voltage measurements must be taken at the module's terminals, as shown above. If sockets are needed, Kelvin connections are required at the module terminals to avoid measurement errors due to socket contact resistance.

SMQ7862

Typical Characteristics (Output=5V):

General Conditions: Input: 2200uF AL+100uF TAN+10uF Ceramic; Output: 200uF AL+10uF Ceramic

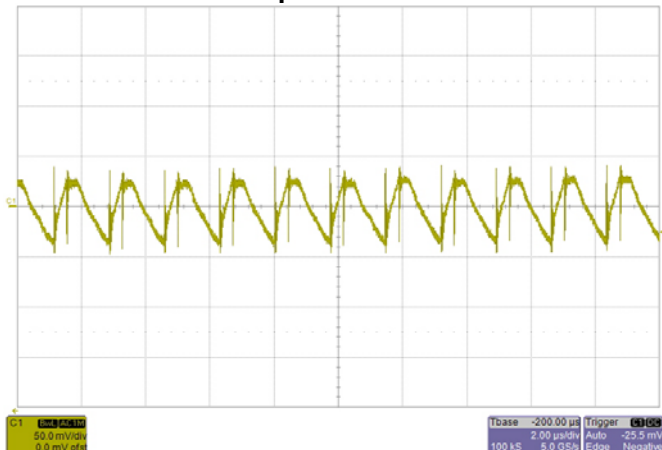

Ripple and Noise (0~20MHz)  
Input: 3.3V, Output: 5V, Load: 2A

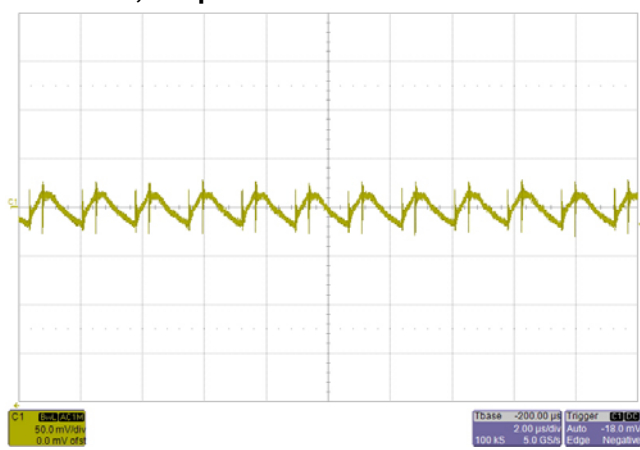

Ripple and Noise (0~20MHz)  
Input: 3.3V, Output: 5V, Load: 1A

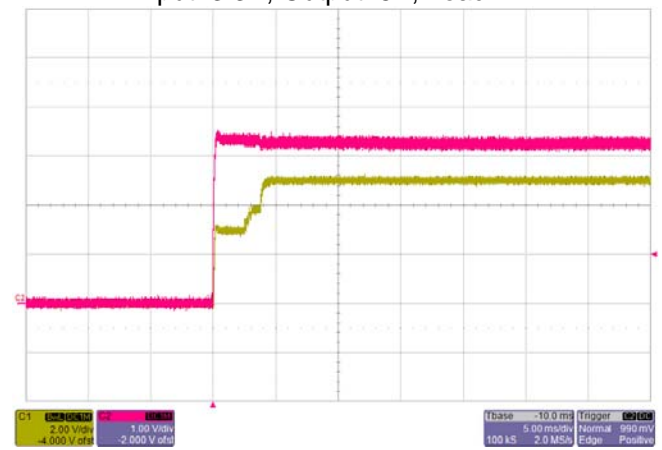

Start-up Input:3.3V

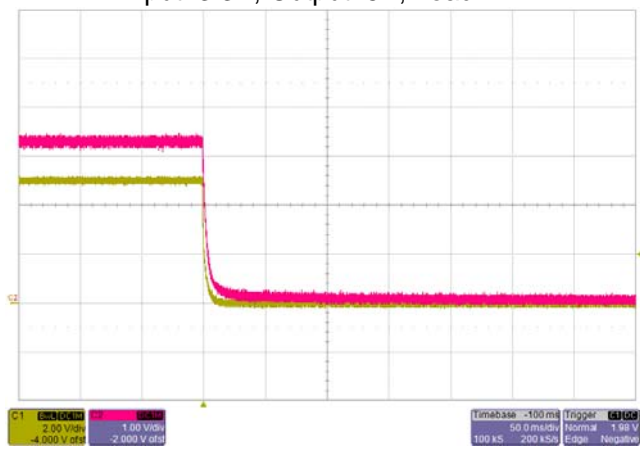

Shutdown Input:3.3V

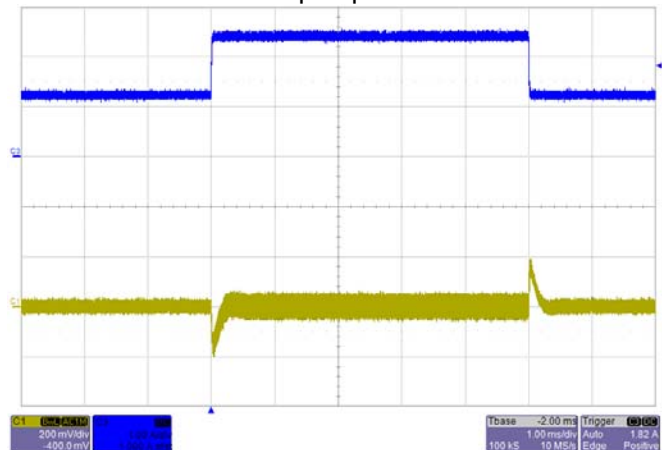

Transient Response (C1: output, C3: Load Current)  
Load current Step from 1A~2A~1A, 0.1A/uS  
Input: 3.3V

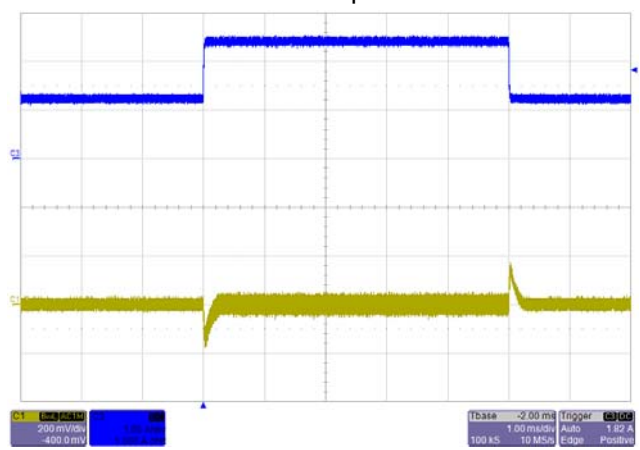

Transient Response (C1: output, C3: Load Current)  
Load current Step from 1A~2A~1A, 0.1A/uS  
Input: 3.6V

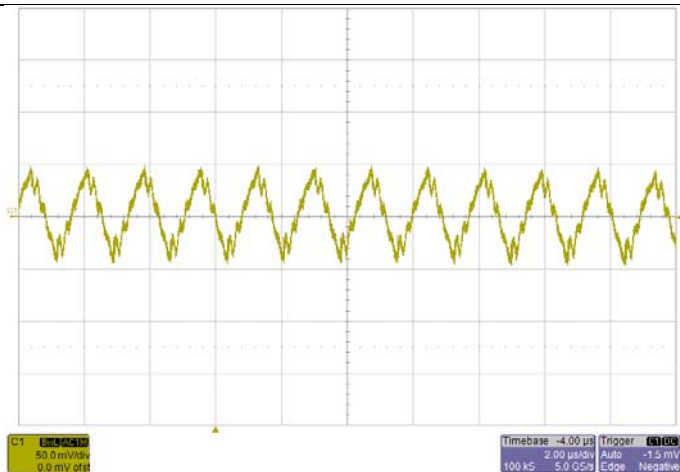

Ripple and Noise (0~20MHz)  
Input: 3.6V, Output: 5V, Load: 2A

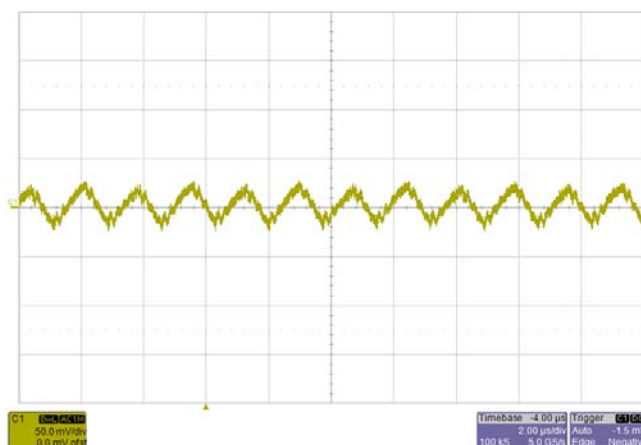

Ripple and Noise (0~20MHz)  
Input: 3.6V, Output: 5V, Load: 1A

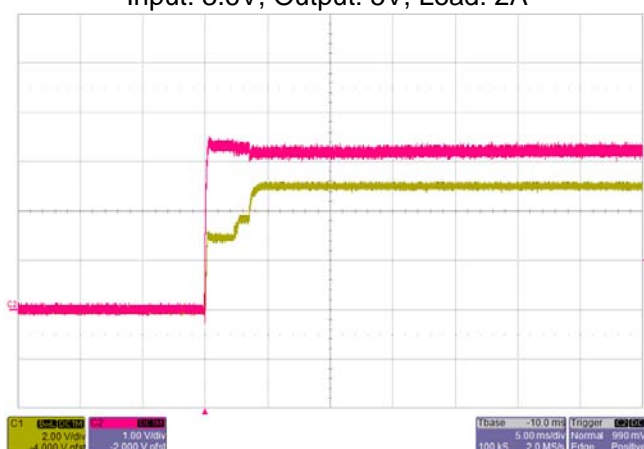

Start-up Input:3.6V

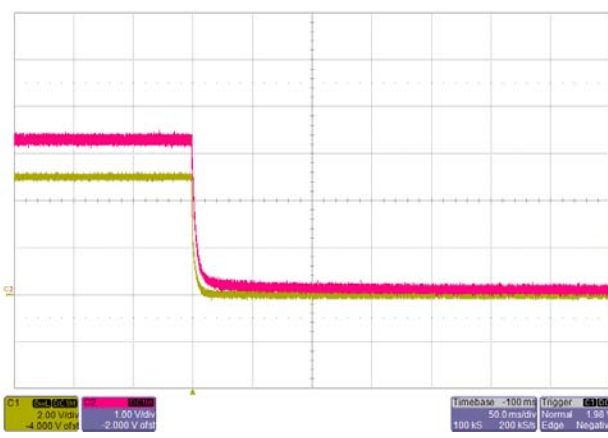

Shutdown Input:3.6V

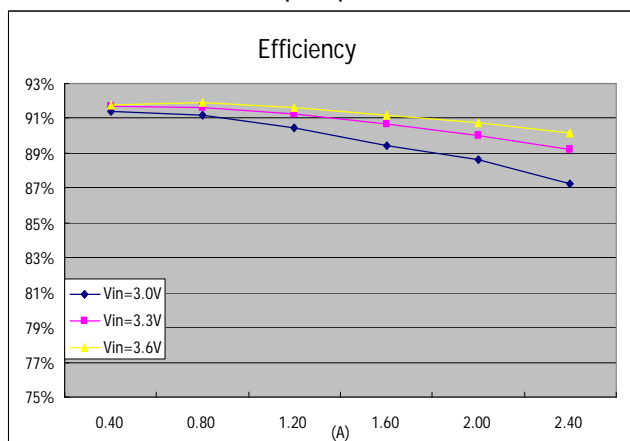

Efficiency

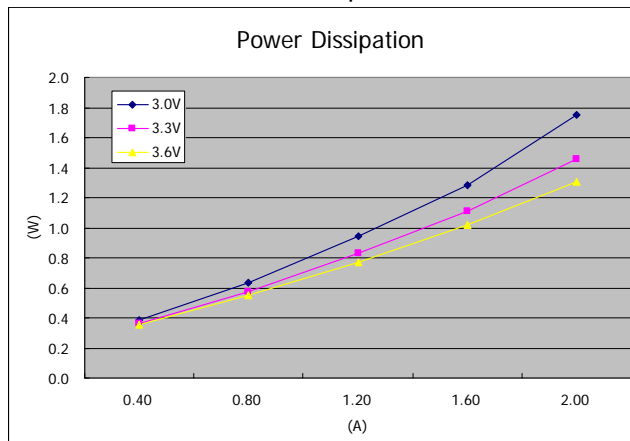

Power Dissipation

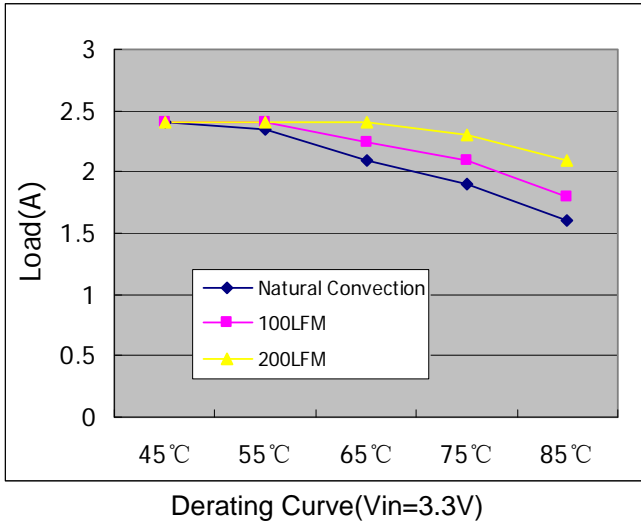



**Typical Characteristics (Output:12V):**

**General Conditions: Input: 2200uF AL+100uF TAN+10uF Ceramic; Output: 200uF AL+10uF Ceramic**

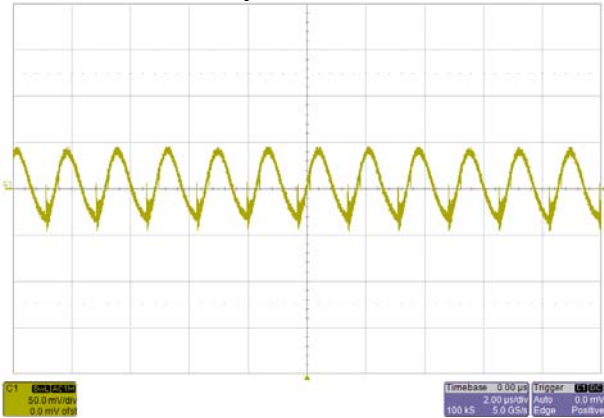

Ripple and Noise (0~20MHz)  
Input: 3.3V, Output: 12V, Load: 1A

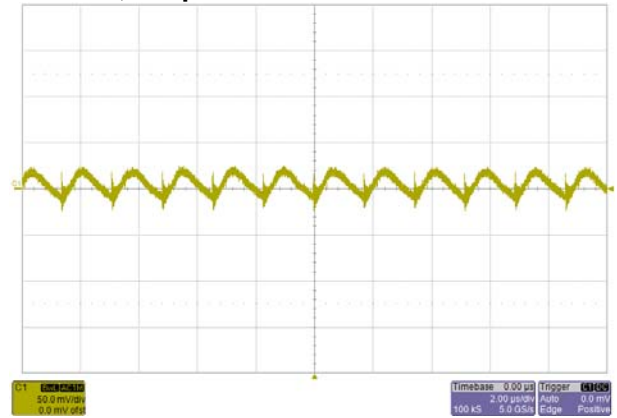

Ripple and Noise (0~20MHz)  
Input: 3.3V, Output: 12V, Load: 0.5A

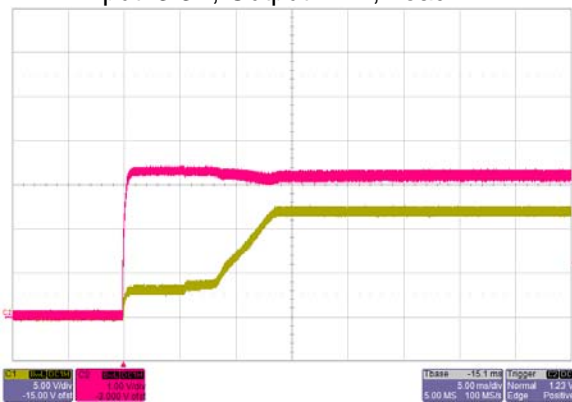

Start-up Input:3.3V

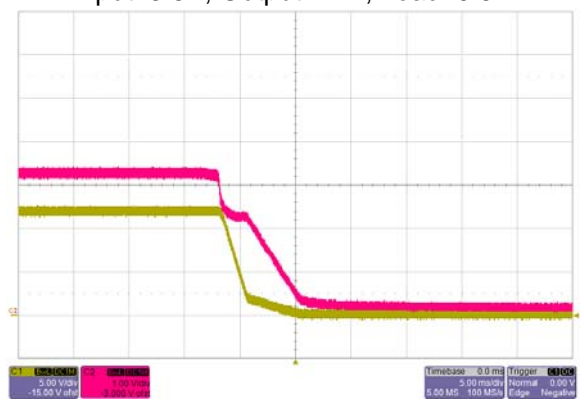

Shutdown Input:3.3V

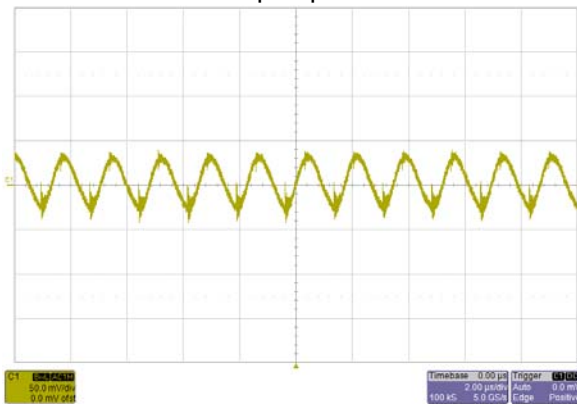

Ripple and Noise (0~20MHz)  
Input: 5.0V, Output: 12V, Load: 1A

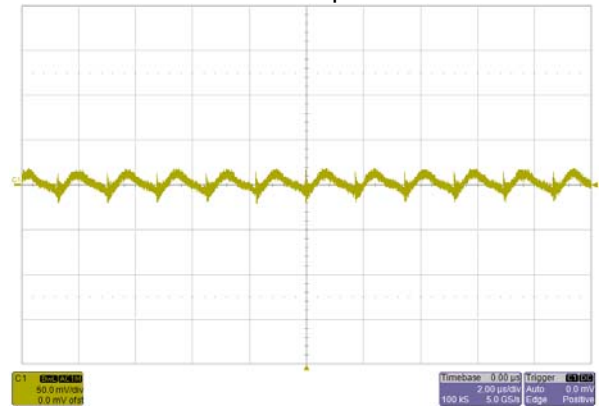

Ripple and Noise (0~20MHz)  
Input: 5.0V, Output: 12V, Load: 0.5A

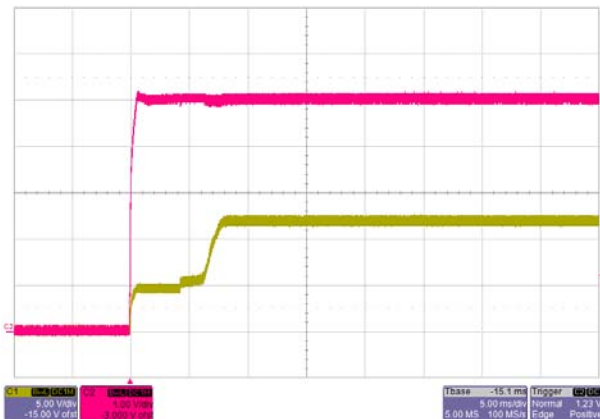

Start-up Input: 5.0V

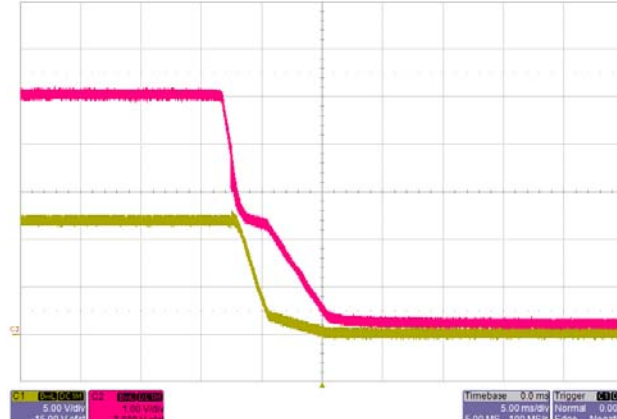

Shutdown Input: 5.0V

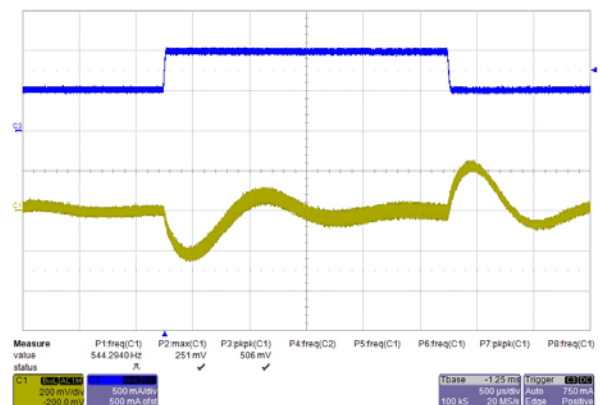

Transient Response (C1: output, C3: Load Current)  
Load current Step from 0.5A~1A~0.5A, 0.1A/uS  
Input: 3.3V, Output: 12V

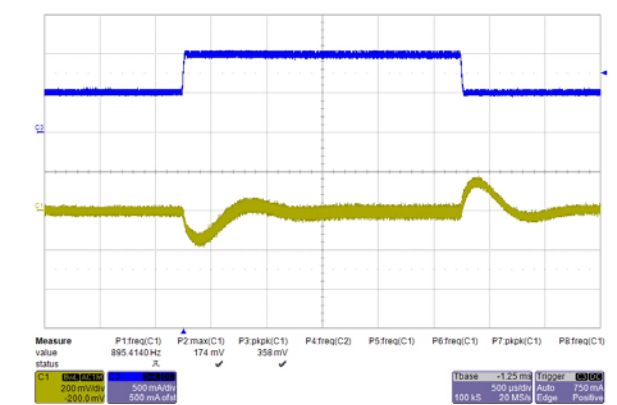

Transient Response (C1: output, C3: Load Current)  
Load current Step from 0.5A~1A~0.5A, 0.1A/uS  
Input: 5.0V, Output: 12V

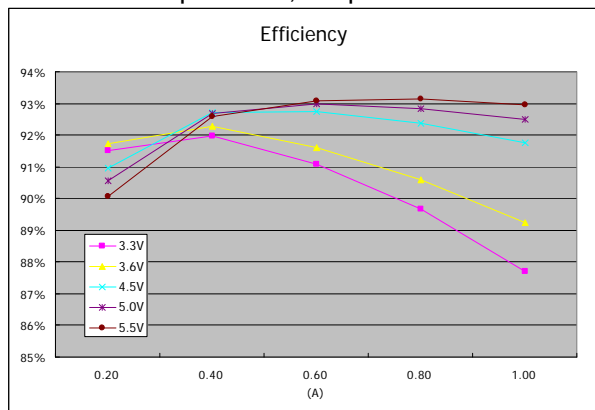

Efficiency

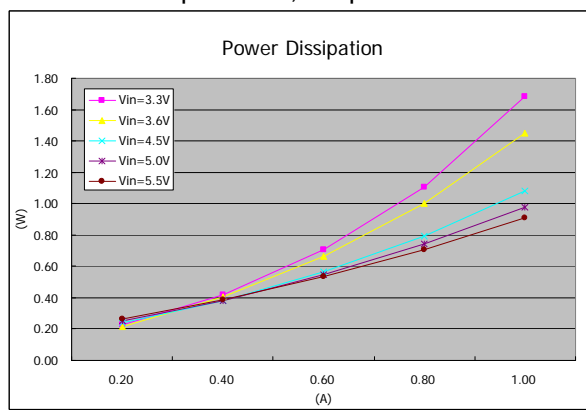

Power Dissipation

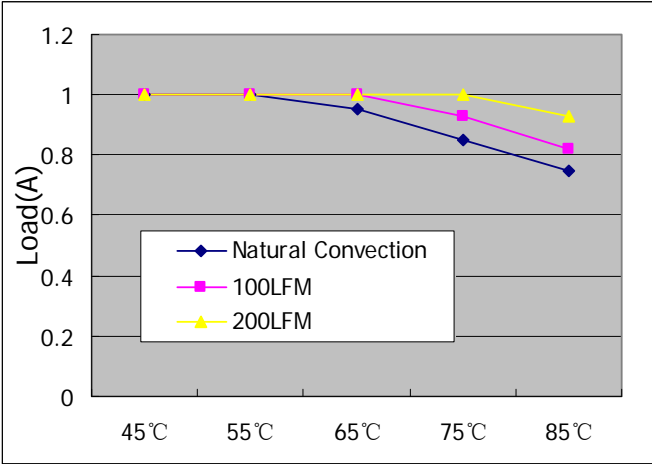

Derating Curve (Vin=3.3V)

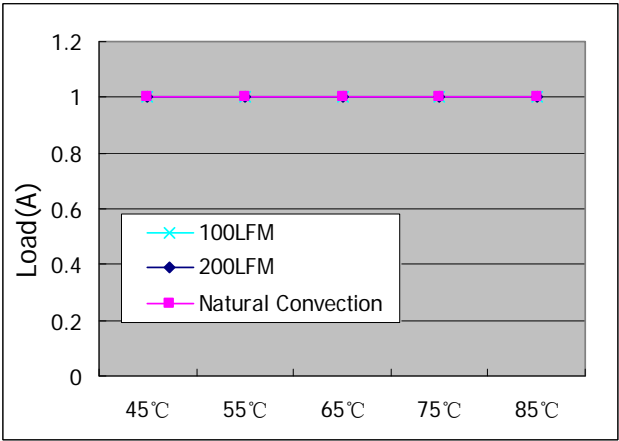

Derating Curve (Vin=5.0V)

**Recommended Hole Pattern**

Dimensions are in inches (millimeters)

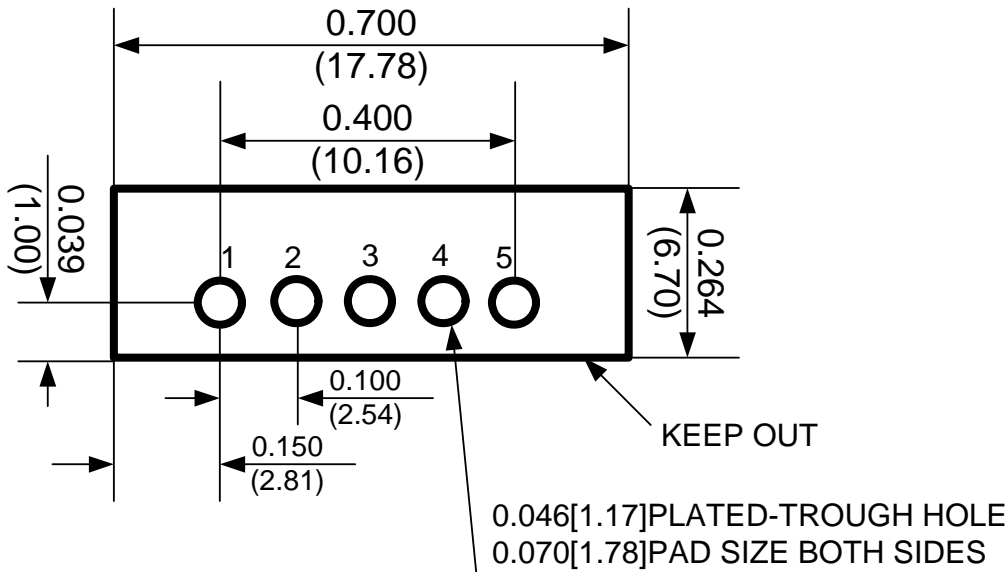

**Component-side footprint for Through-Hole Pin Out**

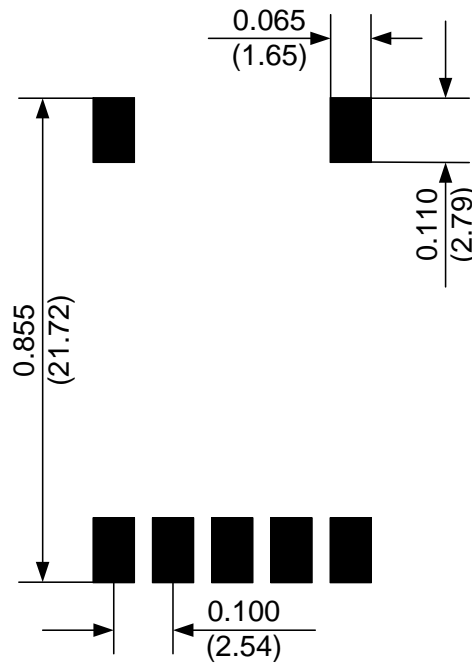

**Component-side footprint for SMT Pin OUT**

Application Notes