

All material is RoHS

REV	LTR	ECN/DESCRIPTION	DATE	APPROVED
A	-	NEW RELEASE	2022.05.20	KIM

PROTECTION DEGREE

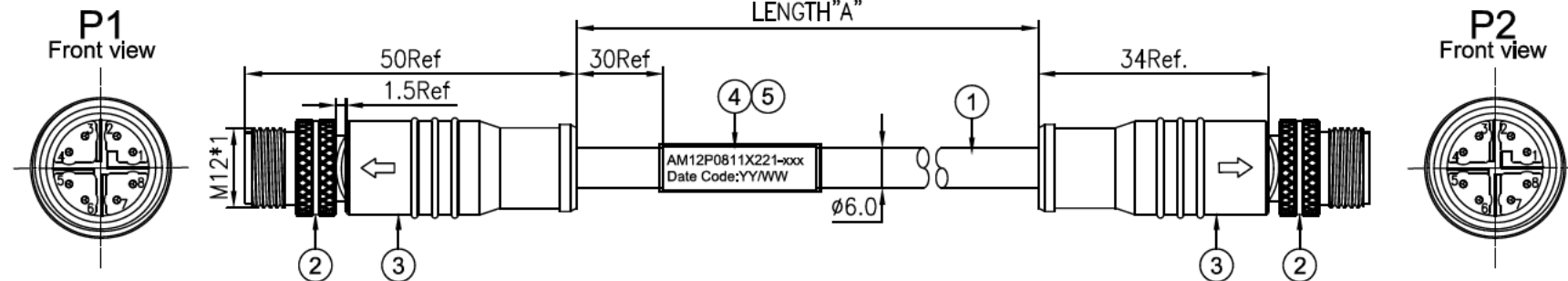

Notes:

1. Connectors:
 - 1.1 Standard: IEC61076-2-109
 - 1.2 Rated voltage: 60V/DC
 - 1.3 Rated current: 0.5A
 - 1.4 Contact material: Brass with gold plated
 - 1.5 Insulation material: PA,Black
 - 1.6 Housing material: Brass with nickel plated
 - 1.7 Durability: >100 Times Cycles
 - 1.8 Temperature range: -40°C~+85°C
2. Electrical testing conditions:
 - 2.1 Voltage: 300V DC/0.1Sec
 - 2.2 100% Open, Short & Miswiring test
3. Marked with "⊕" is the key dimension
4. CAT6A transmission rate up to 10Gbps

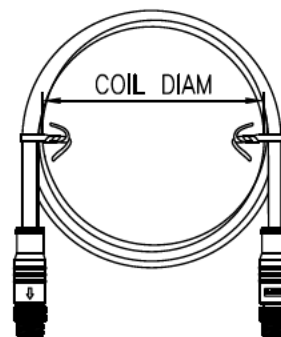
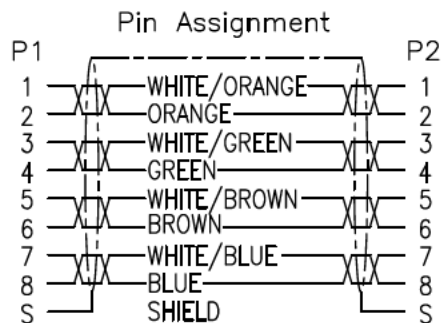

After the cable are bundled, in carton

SM CAB AM12P08 11x221-L	Y
Part No.	⊕ LENGTH "A" INNER COIL DIAM LABEL

ITEM	PART NO.	NAME	DESCRIPTION	Q'TY	TOLERANCE	APPROVALS	DATE
5	E25036	TUBE	TRANSPARENT SHRINK TUBE OD6.0*40mm	1			
4	P21197	LABEL	30*50mm WHITE LABEL, WITH PART NO INFO.	1		DRAWN Johnson	2022.05.20
3	S03010	TPU	OUTER OVERMOLDING BLACK 85A TPU	20g	X. ±0.25 X.X ±0.15 X.XX ±0.10	CHECKED Vanda	2022.05.20
2	M12M0811X002	CONN.	M12 8P MALE, X CODE, SOLDER MOLDING TYPE, WITH SHIELD BACKSHELL	2	ANGULAR ±1°	APPROVED	2022.05.20
1	C83003	CABLE	CAT6A UL20963 26AWG*4PR+ADB, OD6.0mm, TPU WATER BLUE (RAL5021)	1			
					UNLESS OTHERWISE SPECIFIED	DWG TYPE	PROJECT CODE PHD

SCHMID-M

TITLE M12 PRE-MOLDED CABLE, 8P, X CODE, STRAIGHT, ETHERNET CABLE ASSEMBLY, WATER BLUE

UNIT	SIZE	PART No.
mm	A4	-
SCALE	SHEET	DWG No.
Free	1 OF 1	-

REV. A