

REV.	LOCAS.	DESCRIPTION	DATE	DRAWN

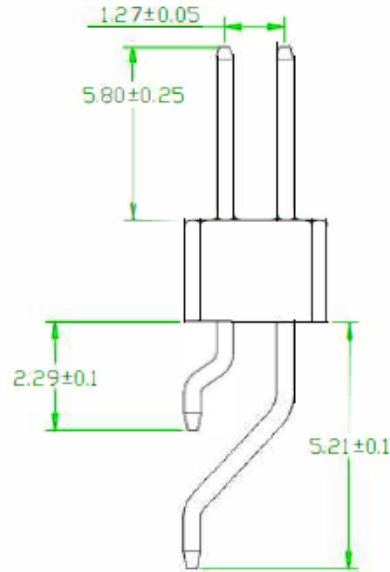
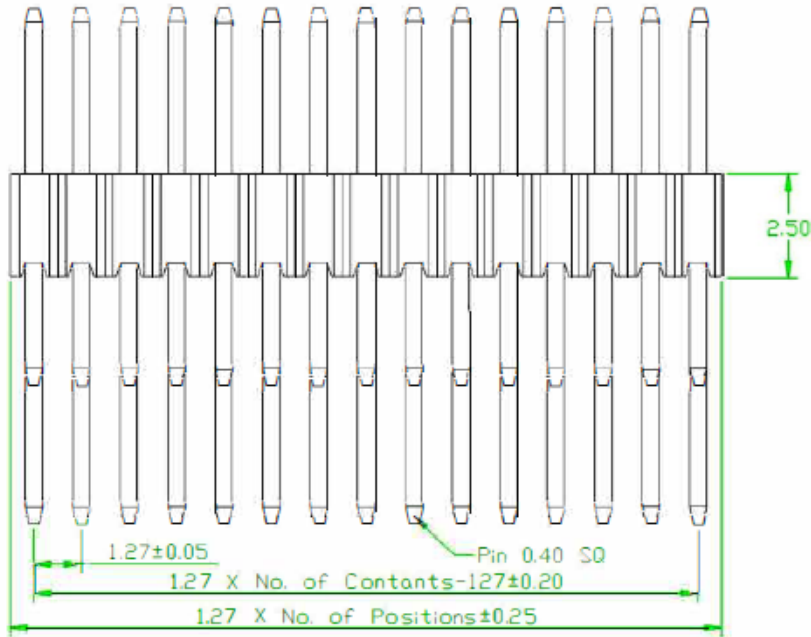
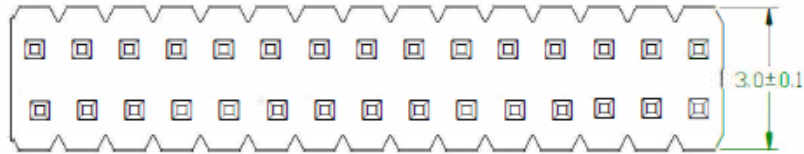

**Specifications**  
 Current Rating: 1Amp  
 Insulation Resistance: 1000MΩ Min.  
 Dielectric Withstanding: 300V AC  
 Contact Resistance: 20mΩ Max.  
 Operating Temperature: -40°C to +105°C

**Materials**  
 Contact Material: Brass, Gold Flash  
 Insulation Material: Polyester, UL 94V-0  
 NYLON-6T  
 All materials must be GP materials

**RECOMMENDED P.C.B LAYOUT**

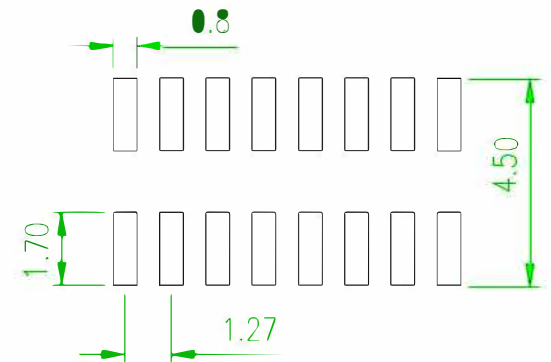

**SCHMID-M**

REV.	01	UNIT.	mm	SCALE.	5:1	PAGE.	1/1	
------	----	-------	----	--------	-----	-------	-----	--

GENERAL TOLERANCE	
X.* ± 5.0°	X. ± 0.30
.X* ± 3.0°	.X ± 0.25
.XX* ± 2.0°	.XX ± 0.15
.XXX* ± 1.0°	.XXX ± 0.10

DESIGN:	DATE: 2007.08.02
CHECKED:	DATE:
AUDITED:	DATE:
APPROVED:	DATE:

DWG. NO.	
PART NO.	

<b>SM C02 1276 XX T&amp;R</b>
-------------------------------

TITLE:	1.27 PIN HEADER DUAL ROW SMT TYPE BASE 2.50
--------	---