

1 2 3 4 5 6 7 8

A
B
C
D
E
F
G
H

A
B
C
D
E
F
G
H

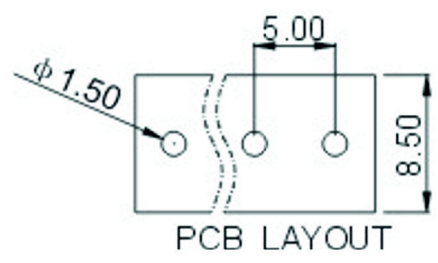
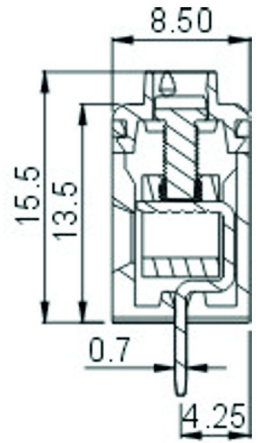
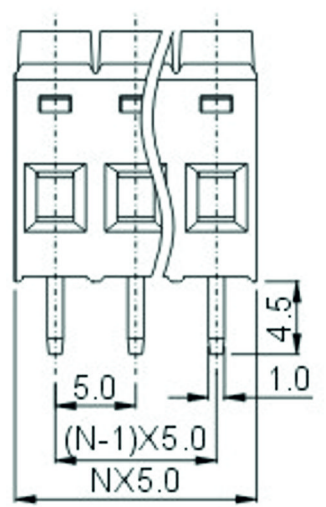

Standard	UL	VDE
Rated voltage	300V	250V
Rated current	15A	24A
Wire range	28-12AWG	0.5--2.5mm ²
Withstanding voltage	AC2000V/1Min	
Ambient temperature	-40°C~+105°C	
Strip length	7mm	
Torque	0.4Nm(3.5Lb-In.)	
Pitch	5.00 (.197")	
Poles	2P , 20P ---Any poles	
Housing	PA66,UL94V-0	
Screws	M2.5,steel,Cr ³⁺ Zn plated	
Solder Pins	Brass, Tin plated	
Contact Cage	Brass, Ni plated	

Part Number Order :SM C09 15026 XX SSZ -Y

SM C09 15026 - Series
 XX - Number of poles
 SSTerminal Block Style
 Z Color (4:Green 8:White/Grey)
 -YIf omitteddetachable poles
-FFirm Plastic Body

-F ...Firm Plastic Body / Green

Detachable Poles / Grey

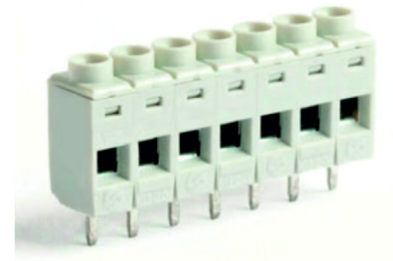

RoHS Compliant		SCHMID-M	
APPD.	SCALE	TOLERANCE	PART NAME
DWG. GRAY	UNIT M M	0 ± .00 ± ANG. ±	Terminal Block, Screw Clamp Style, Hor. Cond., Pitch 5,00mm, PCB Straight
DATE 2014/01/30	PAGE 1 OF 1	SIZE A 4 REV. A	PART NO. SM C09 15026 XX SSZ-Y

1 2 3 4 5 6 7 8