



FEATURES

- Wide range Input voltage 90 - 264VAC or 120 - 370VDC
- Accepts AC or DC input (dual-use of same terminal)
- Operating ambient temperature range: -40°C to +70°C (Non-condensing)
- High reliability, efficiency up to 94%
- 1 U height
- Wide range of adjustable output voltage
- Output short circuit, over-current, over-voltage protection, over-temperature protection
- Support 3+1 parallel redundancy, current sharing
- Built-in active PFC function
- Operating up to 5000m altitude
- Fan speed automatic adjustable

RoHS

SLMF1000-20Bxx series is one of SCHMID-M's enclosed AC-DC switching power supply. It features universal AC input and at the same time accepts DC input voltage, cost-effective, low no load power consumption, high efficiency, high reliability and double or reinforced insulation. These converters offer excellent EMC performance and meet IEC/EN61000-4, CISPR32/EN55032, IEC/UL/EN62368, EN60335, EN60601, GB4943 standards and they are widely used in areas of industrial, LED, street light control, electricity, security, telecommunications, smart home, etc.

Selection Guide*

Certification	Part No.*	Output Power (W)		Nominal Output Voltage and Current (Vo/Io)	Main Output Voltage Adjustable Range ADJ (V)	Efficiency at 230VAC (%) Typ.	Max. Capacitive Load (µF)
		960	Main				
UL/EN/IEC (Pending)	SLMF1000-20B12	960	Main	12V/80A	12-14.4	92	40000
		10	Auxiliary	5V/2A	/		1000
	SLMF1000-20B15	960	Main	15V/64A	15-18		20000
		10	Auxiliary	5V/2A	/		1000
	SLMF1000-20B24	1008	Main	24V/42A	24-28.8	94	10000
		10	Auxiliary	5V/2A	/		1000
	SLMF1000-20B27	1007	Main	27V/37.3A	27-32.4		8000
		10	Auxiliary	5V/2A	/		1000
	SLMF1000-20B36	1008	Main	36V/28.8A	36-43.2	6000	
		10	Auxiliary	5V/2A	/	1000	
	SLMF1000-20B48	1008	Main	48V/21A	48-56	4000	
		10	Auxiliary	5V/2A	/	1000	
	SLMF1000-20B54	1009	Main	54V/18.7A	54-58	3000	
		10	Auxiliary	5V/2A	/	1000	

Note: 1.*For all applications, please refer to SLMF1000-20B(-Q) Series Power Supply Application Notes.
2.*Use suffix "Q" for conformal coating.

Input Specifications

Item	Operating Conditions		Min.	Typ.	Max.	Unit
Input Voltage Range	AC input		90	--	264	VAC
	DC input		120	--	370	VDC
Input Voltage Frequency			47	--	63	Hz
Input Current	115VAC		--	--	12	A
	230VAC		--	--	6	
Inrush Current	115VAC		Cold start		--	
	230VAC		--	40	--	

AC/DC1000W Enclosed Switching Power Supply

SLMF1000-20Bxx(-Q) Series

Power Factor	115VAC	Room-temperature, full load	PF \geq 0.99
	230VAC		PF \geq 0.95
Contact Leakage Current	240VAC		<0.5mA

Output Specifications

Item	Operating Conditions		Min.	Typ.	Max.	Unit
Output Voltage Accuracy	Main		--	± 1	--	%
	Auxiliary		--	± 2	--	
Line Regulation	Main output full load		--	± 0.5	--	
	Auxiliary output full load		--	± 1	--	
Load Regulation	Main		--	± 0.5	--	
	Auxiliary		--	± 1	--	
Ripple & Noise*	20MHz bandwidth (peak-to-peak value)	12V/15V/24V/27V	--	150	--	mV
		36V/48V/54V	--	200	--	
		Auxiliary	--	100	--	
Temperature Coefficient			--	± 0.03	--	%/ $^{\circ}$ C
Short Circuit Protection			Hiccups, continuous, self-recover			
Over Current Protection			$\geq 110\%I_o$, self-recover			
Over Voltage Protection	12V		$\leq 16.5V$	(Output voltage turn off, re-power on for recover or PS_ON signal control recover)		
	15V		$\leq 21V$			
	24V		$\leq 33V$			
	27V		$\leq 35V$			
	36V		$\leq 48V$			
	48V		$< 60V$			
	54V		$\leq 63V$			
	Auxiliary		$< 7V$ (hiccup, self-recover)			
Over-temperature Protection	Over-temperature Protection Activation		--	--	70	$^{\circ}$ C
	Over-temperature Protection Deactivation		50	--	--	
Minimum Load			0	--	--	%
Dynamic minimum load			10	--	--	
Hold-up Time	Room-temperature, full load	115VAC	--	12	--	ms
		230VAC	--	12	--	
Fan	The fan speed is determined by the ambient temperature and output power and linearly adjusted					

Note: *The "Tip and barrel method" is used for ripple and noise test, output parallel 47 μ F electrolytic capacitor and 0.1 μ F ceramic capacitor, please refer to Enclosed Switching Power Supply Application Notes for specific information.

General Specifications.

Item	Operating Conditions		Min.	Typ.	Max.	Unit
Isolation Test	Input - output	Electric Strength Test for 1min., leakage current <10mA	4000	--	--	VAC
	Input - \oplus		2000	--	--	
	Output - \oplus		1500	--	--	
Insulation Resistance	Input - output	Environment temperature: 25 \pm 5 $^{\circ}$ C, Relative humidity: <95%RH, non-condensing Testing voltage: 500VDC	100	--	--	M Ω
	Input - \oplus		100	--	--	
	Output - \oplus		100	--	--	
Operating Temperature			-40	--	+70	$^{\circ}$ C
Storage Temperature			-40	--	+85	
Storage Humidity			10	--	95	%RH
Operating Humidity	Non-condensing		20	--	90	
Switching Frequency	PFC circuit		--	65	--	kHz
	LLC circuit		--	100	--	

AC/DC1000W Enclosed Switching Power Supply

SLMF1000-20Bxx(-Q) Series

Power Derating	Operating temperature derating	-40°C to -30°C	5.0	--	--	%/ ^o C	
		+45°C to +70°C	12V/15V	1.6	--		--
		+50°C to +70°C	24V/27V/36V /48V/54V	2.0	--		--
	Input voltage derating	90VAC to 100VAC	2.0	--	--	%/VAC	
Safety Standard					Design refer to IEC/UL/EN62368-1 IEC/ES/EN60601-1-2:2015 Edition 4		
Safety Class					CLASS I		
Isolation level	Input - output					2 x MOPP	
	Input - ⊕					1 x MOPP	
	Output - ⊕					1 x MOPP	
MTBF	MIL-HDBK-217F@25°C					≥250,000 h	

Mechanical Specifications

Case Material	SUS 304
Dimensions	190.0 x 127.0 x 40.5 mm
Weight	1.25Kg (Typ.)
Cooling Method	Forced cooling

Electromagnetic Compatibility (EMC)

Emissions	CE	CISPR32/EN55032 CLASS B	
	RE	CISPR32/EN55032 CLASS B	
	Harmonic current	EN61000-3-2 CLASS A	
	Flicker	IEC/EN61000-3-3	
Immunity	ESD	IEC/EN 61000-4-2 Contact ±6KV/Air ±8KV	perf. Criteria A
	RS	IEC/EN 61000-4-3 10V/m	perf. Criteria A
	EFT	IEC/EN 61000-4-4 ±2KV	perf. Criteria A
	Surge	IEC/EN 61000-4-5 line to line ±2KV/line to ground ±4KV	perf. Criteria A
	CS	IEC/EN61000-4-6 10 Vr.m.s	perf. Criteria A
	Voltage dips, short interruptions and voltage variations	IEC/EN61000-4-11 0%, 70%	perf. Criteria B

Note: *The power supply should be considered as a part of the components in the system. RE performance are been tested on a metal plate with a thickness of 3mm and a length of 450mm x 450mm. The power supply must be combined with the terminal equipment for electromagnetic compatibility confirmation.

Functional Specifications

Item	Operating Conditions	Min.	Typ.	Max.	Unit	
Remote Control Switch	All Input Voltage Range All load range	Power On	PS_ON (CN2 Pin6) and GND (CN2 Pin7/14) are short		/	
		Power Off	PS_ON (CN2 Pin6) and GND (CN2 Pin7/14) are open			
DC_OK Signal	All Input Voltage Range All load range	Power On	2.5	--	5	V
		Power Off	--	--	0.5	
Oring					Support direct parallel use, achieve 3+1 parallel redundancy	
Current Sharing Accuracy	When units in parallel, each power supply needs to carry a rated load of more than 50%	--	±10	--	%	
LED Signal	Main output status indication	Normal Output	Green on		/	
		Abnormal Output, protected	Red on			
		Power Off (AC Without Input)	Light off			
Remote Sense	Total compensate voltage (Vs+/Vs- shorted to Vo+/Vo- respectively)	--	200	--	mV	
SDA, SCL for I2C					Internal 2.4 kΩ pull-up resistor to internal 3.3 V	

Note: *Please refer to SLMF1000-20Bxx(-Q) Series Power Supply Application Notes for relevant function control logic and instructions.

AC/DC1000W Enclosed Switching Power Supply

SLMF1000-20Bxx(-Q) Series

Product Characteristic Curve

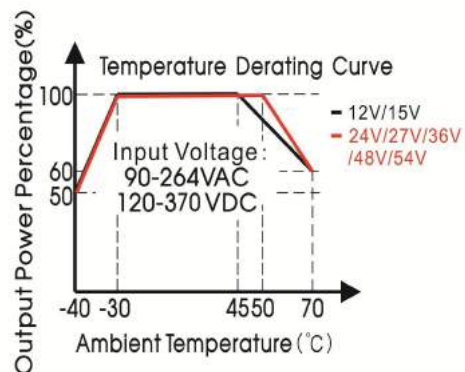
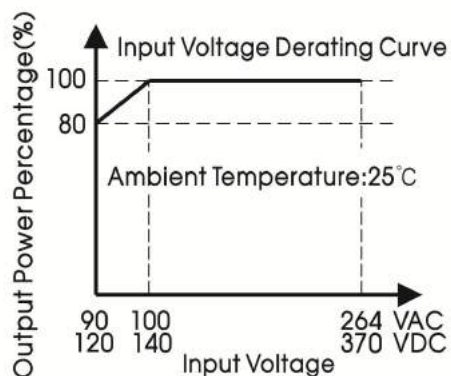

Note: With an AC input voltage between 90-100VAC and a DC input between 120-140VDC the output power must be derated as per the temperature derating curves.

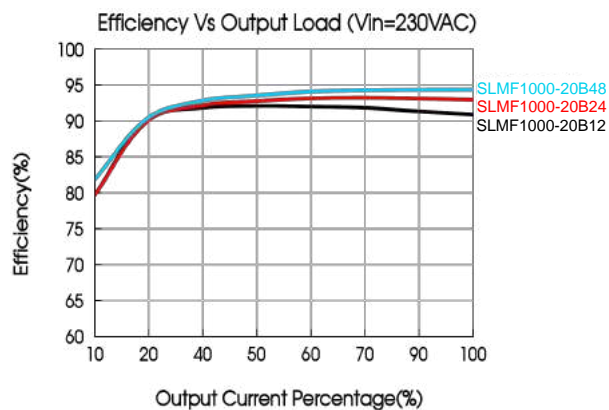
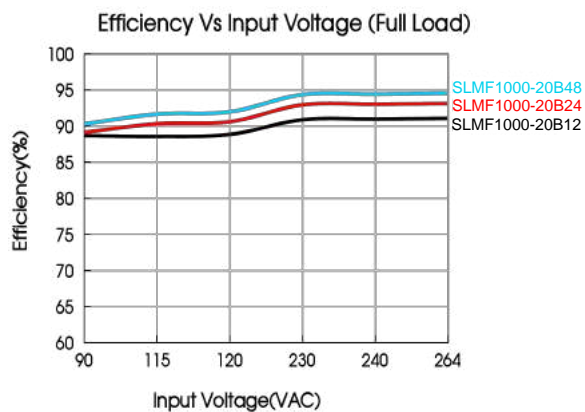

AC/DC1000W Enclosed Switching Power Supply

SLMF1000-20Bxx(-Q) Series

Dimensions and Recommended Layout

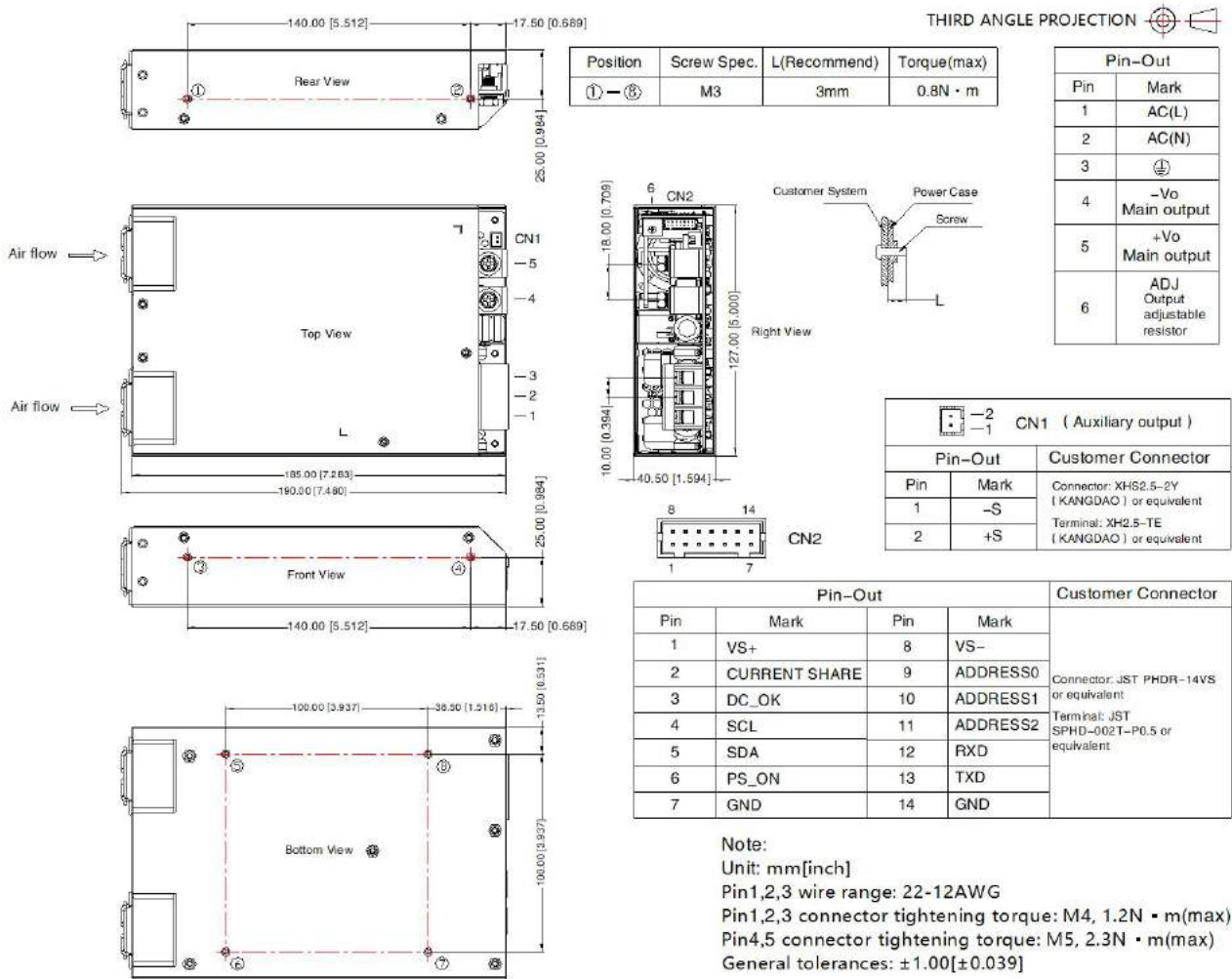

Note:

- Unless otherwise specified, parameters in this datasheet were measured under the conditions of $T_a=25^{\circ}\text{C}$, humidity<75%RH with nominal input voltage and rated output load;
- The room temperature derating of $5^{\circ}\text{C}/1000\text{m}$ is needed for operating altitude greater than 2000m;
- All index testing methods in this datasheet are based on our company corporate standards;
- In order to improve the efficiency at high input voltage, there will be audible noise generated, but it does not affect product performance and reliability;
- We can provide product customization service, please contact our technicians directly for specific information;
- Products are related to laws and regulations: see "Features" and "EMC";
- The out case needs to be connected to PE (⊕) of system when the terminal equipment in operating;
- The output voltage can be adjusted by the ADJ, clockwise to decrease;
- Our products shall be classified according to ISO14001 and related environmental laws and regulations, and shall be handled by qualified units;
- The power supply is considered a component which will be installed into a terminal equipment. All EMC tests should be confirmed with the final equipment. Please consult our FAE for EMC test operation instructions.
- In the appearance dimension drawing, $\pm V_o$ represents the main output, $\pm S$ represents the auxiliary output, and the auxiliary output can be selected by the customer, which has no effect on the main output.

AC/DC1000W Enclosed Switching Power Supply

SLMF1000-20Bxx(-Q) Series



SLMF1000-20Bxx(-Q) Series Power Supply Application Notes

Content

1. Overview.....	8
2. Function Manual.....	12
2.1 Input Requirements.....	12
2.2 Output Requirements.....	12
2.3 Start-up timing.....	12
2.4 Fan Speed Control.....	13
2.5 Output over-voltage protection (OVP).....	13
2.6 Output over-current protection (OCP).....	13
2.7 Output short circuit protection (SCP).....	14
2.8 Over temperature protection (OTP).....	15
2.9 Output power derating.....	15
2.10 Remote control.....	16
2.11 DC_OK Signal.....	17
2.12 Remote compensation.....	18
2.13 Parallel operation.....	18
2.13.1 Redundancy.....	18
2.13.2 Current sharing.....	19
2.14 I2C communication address.....	21
3. Installation requirements.....	22
3.1 Safety introduction.....	22
3.2 Safety requirements.....	22
3.3 Installation method.....	23
4. Communication protocol.....	24

AC/DC1000W Enclosed Switching Power Supply

SLMF1000-20Bxx(-Q) Series

1. Overview

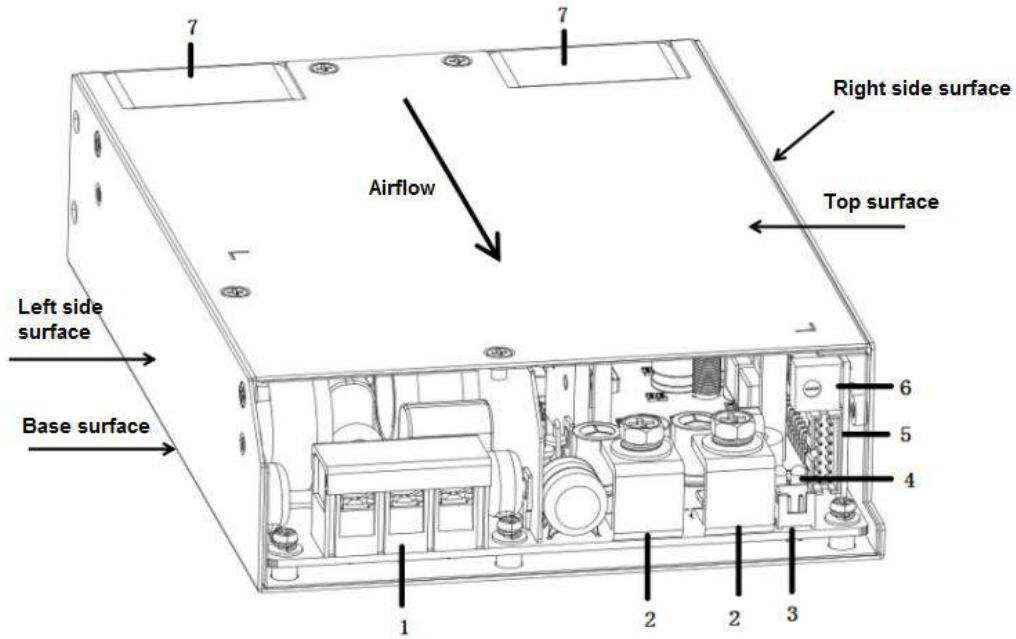

Fig. 1: Appearance information of SLMF1000-20Bxx

Composition structure description

1. AC/DC input terminal (J1)
2. DC main output terminal (J2, J3)
3. Auxiliary road output terminal (CN1)
4. Green and red status display LED lights
5. Signal connection Press the terminal (CN2)
6. Output voltage regulation knob
7. Fans

AC/DC1000W Enclosed Switching Power Supply

SLMF1000-20Bxx(-Q) Series

1.1 AC/DC input terminal block (J1)

The input terminal J1, as a standard 3-pin fence welding terminal with upper cover, the center spacing of the pins is 10mm.

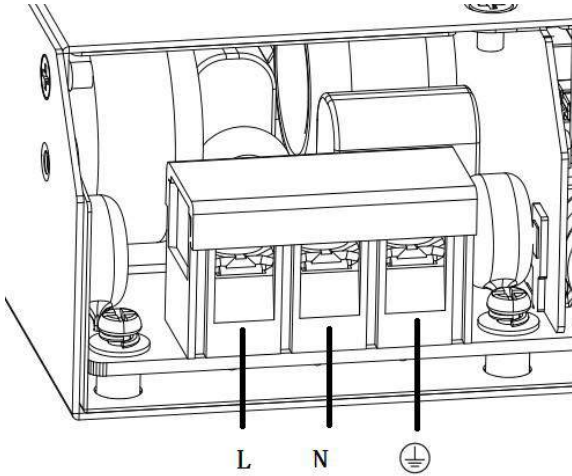

Pin	Features
L	Line (Phase)
N	Neutral
	Ground/Earth

Wire size: 12-18 AWG

Torque: 1.8Nm

1.2 Main DC output terminal (J2)

The output terminal J2, with two standard screw lock type metal terminals, the pin spacing between each is 18mm.

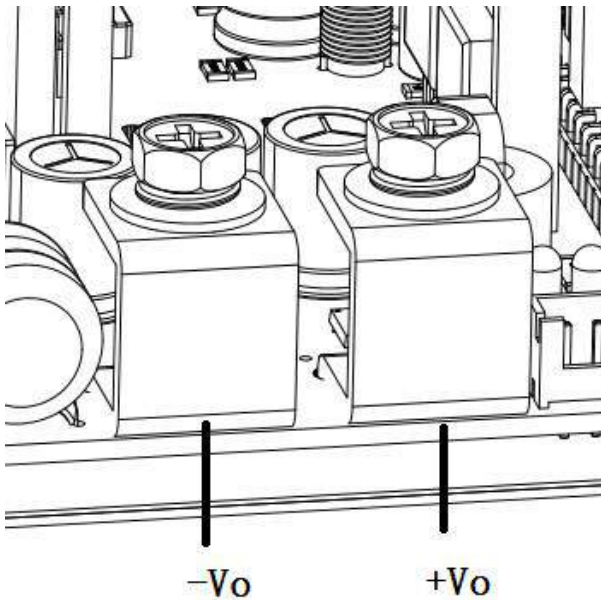

Pin	Features
+Vo	Main Output -
-Vo	Main Output +

Wire size: 4 - 12 AWG

Torque: 2.3Nm

AC/DC1000W Enclosed Switching Power Supply

SLMF1000-20Bxx(-Q) Series

1.3 Auxiliary DC Output Terminal (CN1)

The auxiliary output terminal with a standard terminal of 2.5mm pitch.

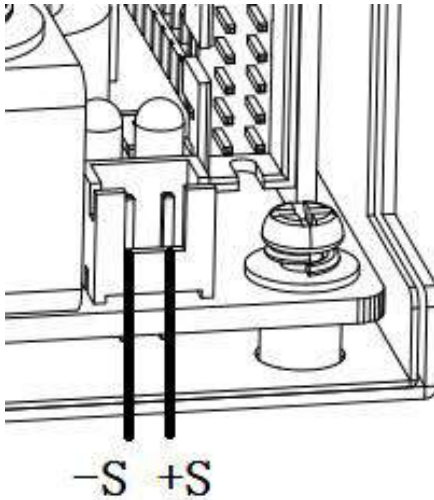

Pin	Function
-S	Auxiliary DC Output -
+S	Auxiliary DC Output +

1.4 Signal port (CN2)

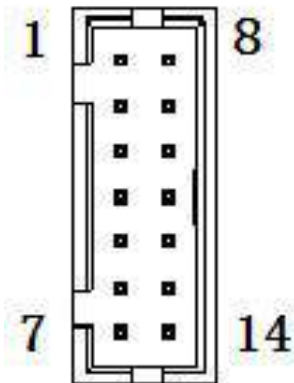

Pin	Label	Features
1	VS+	Remote compensation positive end
2	CURRENT SHARE	Current sharing bus
3	DC_OK	DC_OK Signal
4	SCL	I2C communication line
5	SDA	I2C communication line
6	PS_ON	Remote Control signal
7	GND	Signal terminal reference ground
8	VS-	Remote compensation negative terminal
9	ADDRESS0	ADDRESS code 0
10	ADDRESS1	ADDRESS code 1
11	ADDRESS2	ADDRESS code 2
12	RXD	Serial communication
13	TXD	Serial communication
14	GND	Signal terminal reference ground

Note: The reference ground of all pins on the signal terminal is pin7 and pin8.

AC/DC1000W Enclosed Switching Power Supply

SLMF1000-20Bxx(-Q) Series

1.5 Green and red status display LED lights

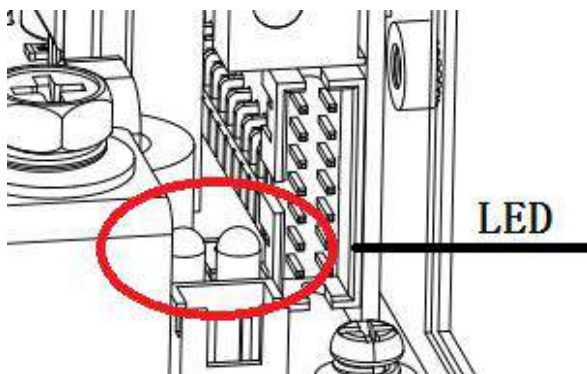

Two kinds of LED lights indicate difference working states of the power supply :

Green LED	Red LED	Status
ON	OFF	Normal work
OFF	ON	Main or auxiliary road alarm
OFF	OFF	No AC input

1.6 Output voltage adjustment knob

Turn counterclockwise to increase output voltage

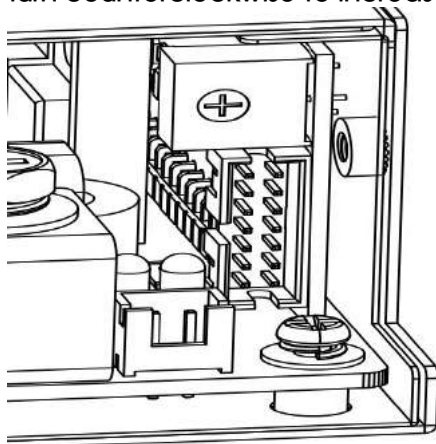

Model	Rated Output Voltage	Adjustable Range Of Output Voltage
SLMF1000-20B12	12V	12 - 14.4V
SLMF1000-20B15	15V	15 - 18V
SLMF1000-20B24	24V	24 - 28.8V
SLMF1000-20B27	27V	27 - 32.4V
SLMF1000-20B36	36V	36 - 43.2V
SLMF1000-20B48	48V	48 - 56V
SLMF1000-20B54	54V	54-58V

AC/DC1000W Enclosed Switching Power Supply

SLMF1000-20Bxx(-Q) Series

2. Function Manual

2.1 Input Requirements

The AC input voltage and DC input voltage must be within the defined voltage range (refer to datasheet), otherwise the power supply may not work properly or even malfunction.

The internal L and N line of the power module have been connected in series with a 250V 20A fuse. For better protection, it is recommended that customers use a circuit breaker not greater than 20A. (Non-mandatory requirement).

2.2 Output Requirements

Main Output

At any voltage value, the maximum output current and power must not exceed the rated/specified value. The output current must not exceed the maximum output current value.

Auxiliary output

The auxiliary circuit supports a maximum current of 2A.

2.3 Start-up timing

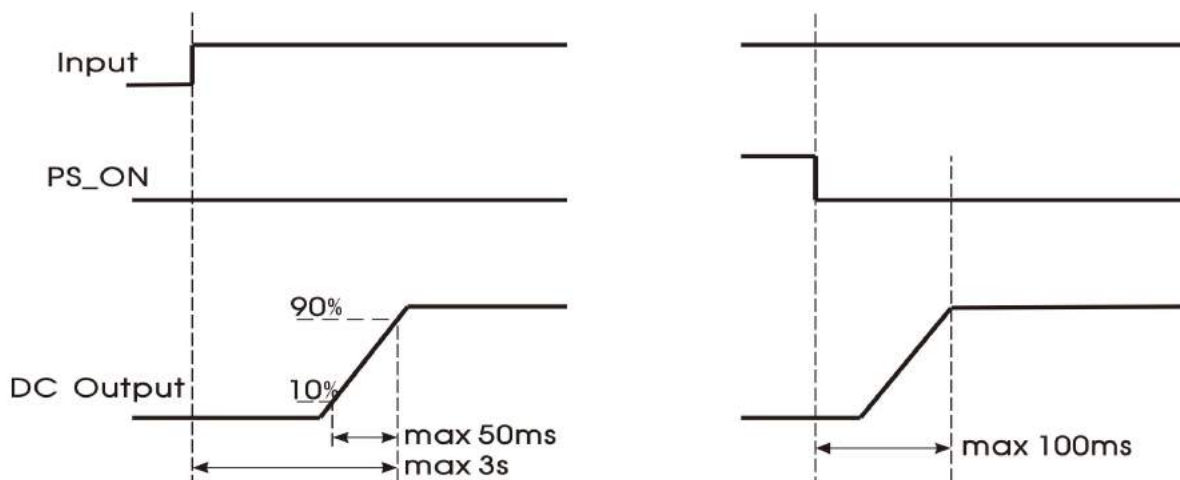

Item	Operating Conditions	Min.	Typ.	Max.	Unit	
Power-off Hold Time	Room temperature, full load	115VAC	--	12	--	ms
		230VAC	--	12	--	
Start Delay Time	230VAC, full load	--	--	3	s	
Output Rise Time	Output voltage from 10%-90%	--	--	50	ms	

AC/DC1000W Enclosed Switching Power Supply

SLMF1000-20Bxx(-Q) Series

2.4 Fan Speed Control

The fan speed is determined by the ambient temperature and output power and linearly adjusted. When the ambient temperature is greater than 45°C and the output power is greater than 600W , the fan reaches 100% speed. In order to improve the reliability of the power supply module, the fan keeps a minimum speed of 10% when the ambient temperature is higher than -5°C under no load; the fan will stop rotating when the ambient temperature is lower than -5°C .

2.5 Output over-voltage protection (OVP)

Main Output

The over-voltage protection function is to close the main output when the output voltage reaches the protection voltage value. When the main circuit over-voltage protection occurs, the main circuit output voltage of the module will be shut off, and the auxiliary circuit output will not be affected. The main circuit output can be restored after disconnecting the input power for at least 30 seconds.

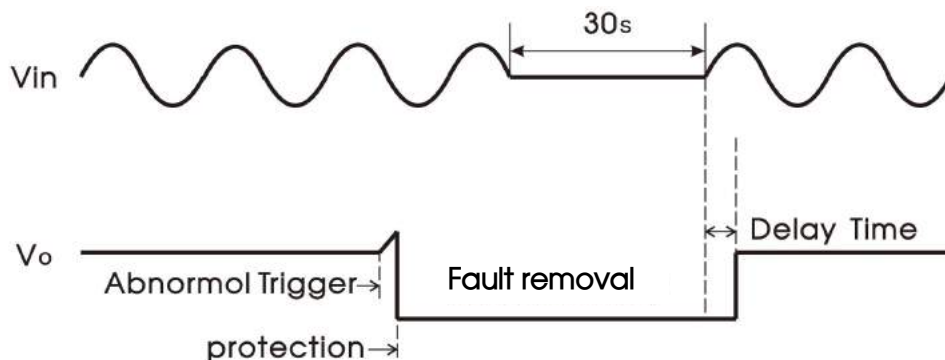

In addition, it can be quickly restarted by the PS_ON signal:

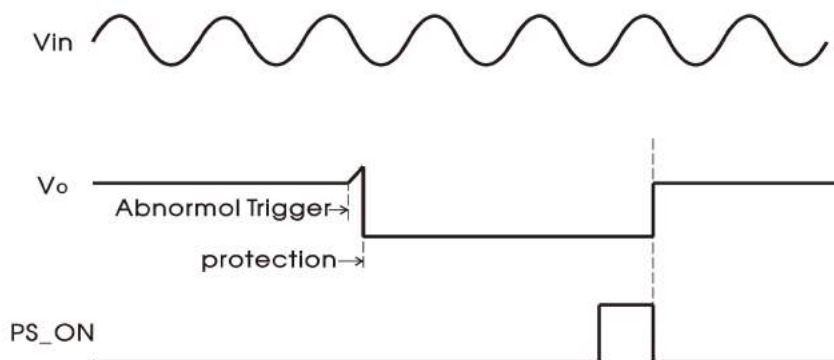

Auxiliary output

When the auxiliary circuit voltage reaches 7Vdc (maximum value), the auxiliary output will be in hiccup status, and the main circuit without output until the auxiliary output returns to normal after the fault is eliminated.

2.6 Output over-current protection (OCP)

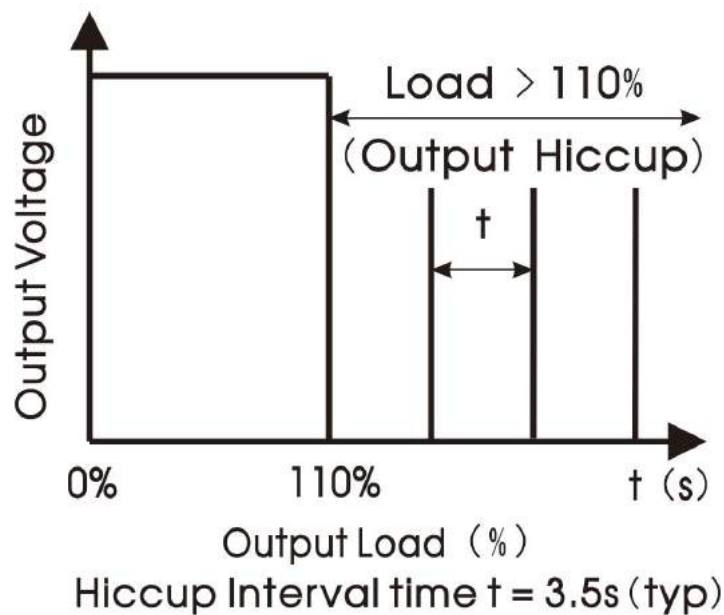

Main output

When the output current exceeds 110% (minimum) of the rated output current, the DC output will be off. The OCP protection function adopts hiccup mode. After the over-current condition is eliminated, the main output will automatically recover, and the auxiliary output will not be affected.

The main circuit output has OCP delay function. When the output current reaches 120% (typical value) of the rated load current 300ms, the main circuit output will be off; when the main circuit output reaches 150% (typical value) of the rated load current 15ms, the main circuit output will be off.

When the output current of the auxiliary circuit exceeds 120% (typical value) of the rated current, the main circuit output will be off. After the over-current state of the auxiliary circuit is eliminated, the main circuit automatically resumes output.

2.7 Output short circuit protection (SCP)

When the output is short-circuited, the power output in hiccup with interval 4.5s. After the short-circuit is removed, the power module will automatically return to normal, and the auxiliary output will not be affected.

When the auxiliary circuit output is short-circuited, the main circuit without output.

AC/DC1000W Enclosed Switching Power Supply

SLMF1000-20Bxx(-Q) Series

2.8 Over temperature protection (OTP)

When the ambient temperature of the power supply exceeds the rated temperature for a period of time, the power supply will be turned off and the power supply will resume normal operation after the ambient temperature drops to the set value.

2.9 Output power derating

When the input voltage is greater than 100VAC (or 140VDC), only need to derate according to the temperature derating curve.

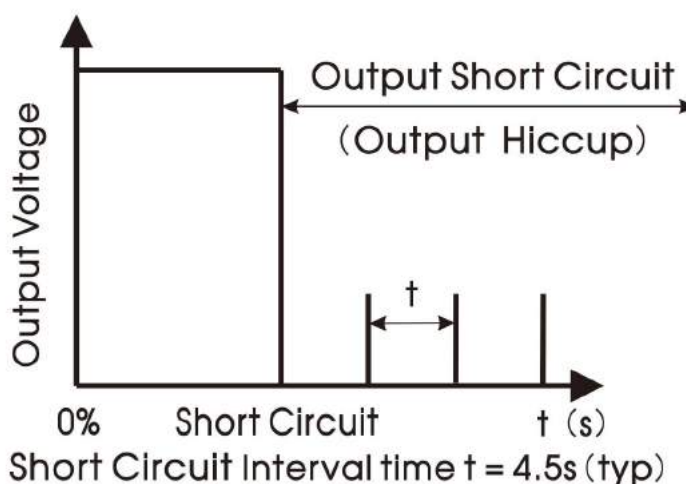

When the input voltage is lower than 100VAC (or 140VDC), the output power will be derated according to the following input voltage derating curve after temperature derating.

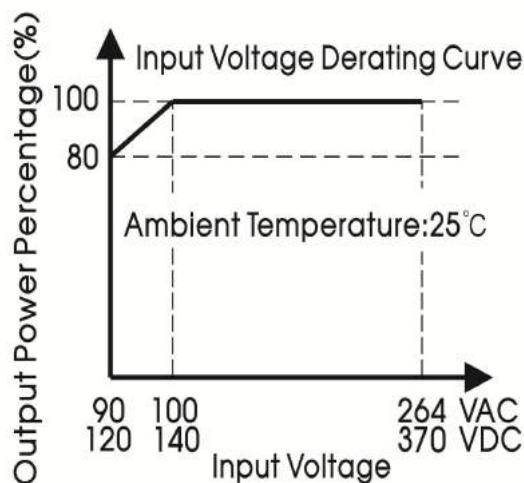
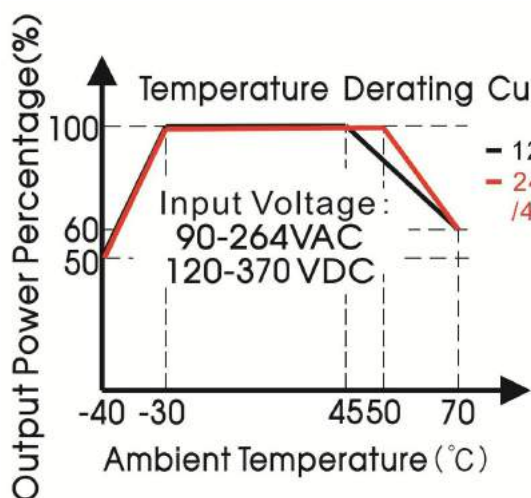

2.10 Remote control

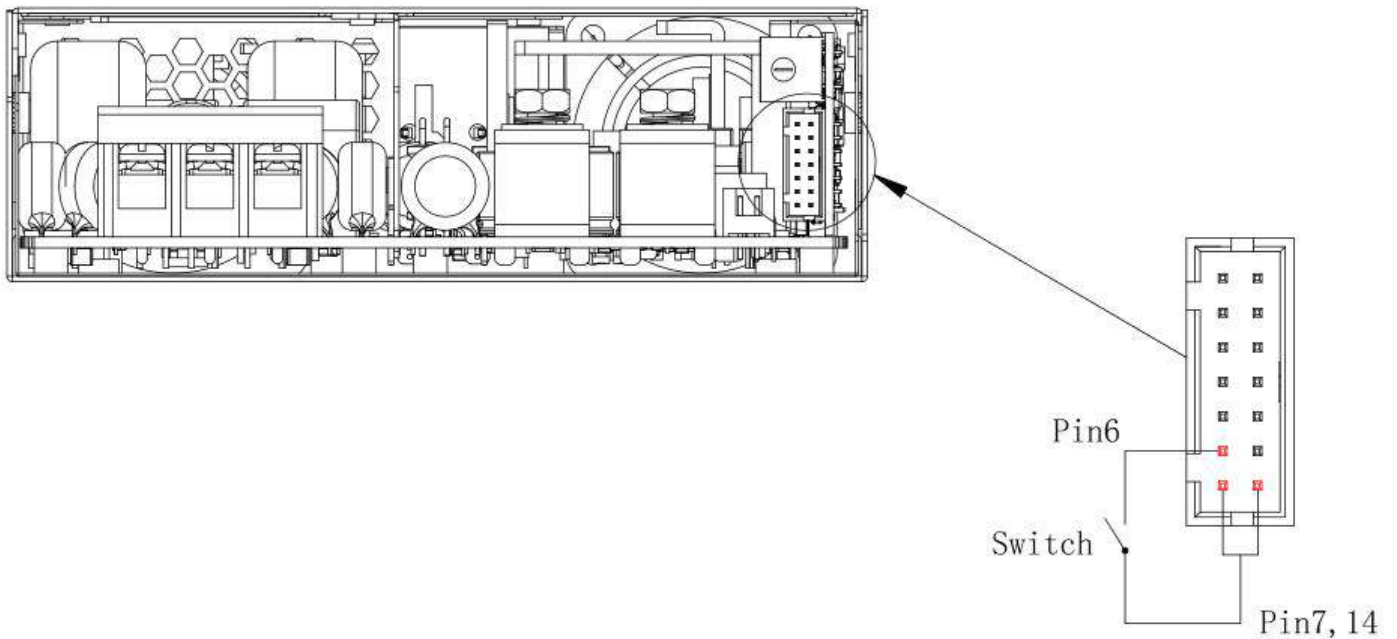

PS_ON (Pin6) and GND (Pin7or Pin14)	Output status
Short-Circuit	ON
Pin Floating	OFF

If the input terminal of the power module has been connected to a power source, the PS_ON signal pin can be used to control the on and off of the main output, and the PS_ON signal does not affect the output voltage of the auxiliary circuit. Note: The internal PS_ON input impedance of the module is 5.1K.

AC/DC1000W Enclosed Switching Power Supply

SLMF1000-20Bxx(-Q) Series

2.11 DC_OK Signal

The DC_OK signal is used to monitor whether the power supply is working normally, and the signal is at Pin3 of the signal terminal CN2.

Note: When the DC_OK signal is connected to the external external circuit (i.e. between Pin3 and Pin7 or Pin14 of CN2) is not less than $10k\Omega$.

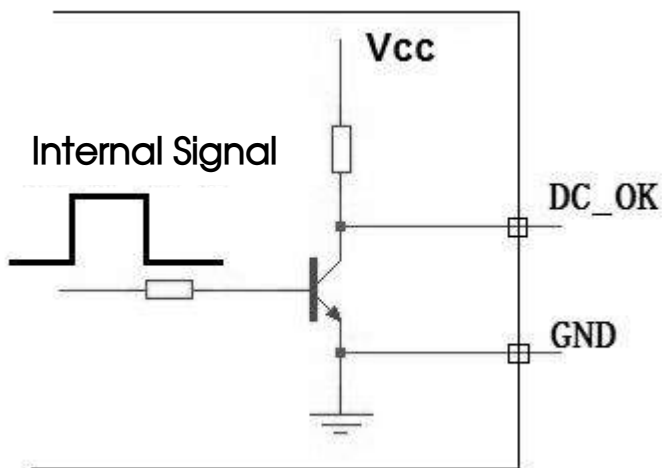
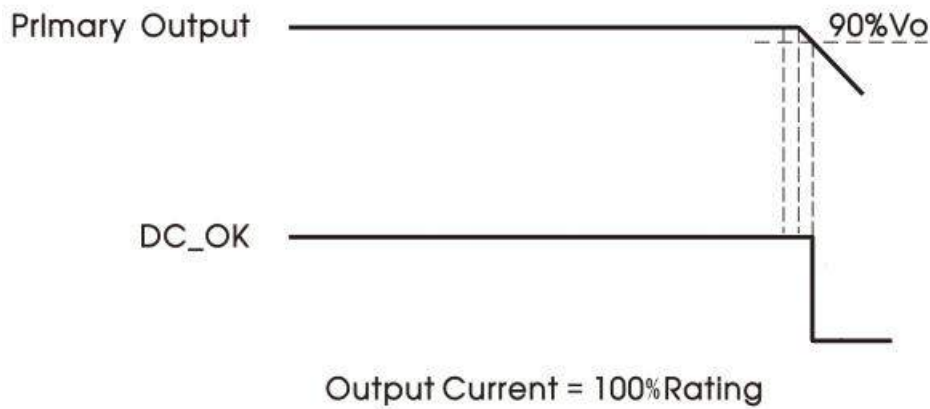

DC_OK (Pin3) and GND (Pin 7 or Pin 14)	Output state
2.5 - 5V	ON
0 - 0.5V	OFF

AC/DC1000W Enclosed Switching Power Supply

SLMF1000-20Bxx(-Q) Series

2.12 Remote compensation

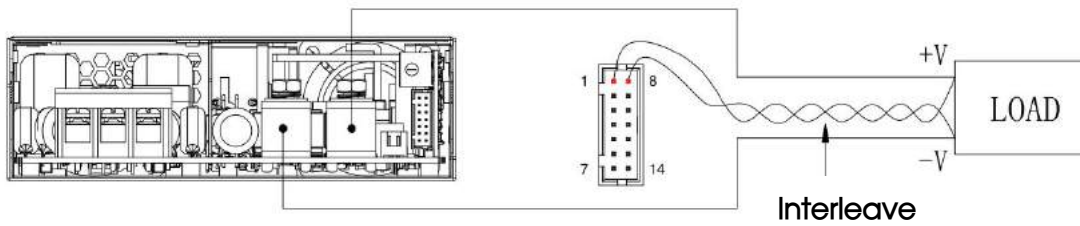

Note: VS+ and VS- cannot be shorted or reversed, otherwise the power module will be damaged.

Pin 1 and pin 8 of the signal terminal CN2 can compensate the voltage drop on the output cable. The remote compensation circuit can compensate up to 200mV cable voltage drop. This voltage includes the sum of the cable drop connected to the output positive terminal and the output negative terminal. If you need to use the near-end compensation function, the signal pin needs to be connected with the load end with a twisted pair, otherwise the power module will be damaged.

2.13 Parallel operation

2.13.1 Redundancy

The power module output can be connected in parallel to achieve redundancy, thereby improving system reliability. The maximum power of the redundant system needs to be derated to ensure that the redundant system can still meet the rated load requirements when a power supply module fails. The current common practice is to construct a redundant system by the N+1 method, that is, N+1 power supplies are connected in parallel, to support the maximum load current $N \cdot I_{\text{omax}}$, where I_{omax} is the rated output current of each power supply. For example, the rated output current of each power supply is 40A, and 3+1 units are connected in parallel to construct a $3 \cdot 40\text{A} = 120\text{A}$ redundant system.

The power module supports 3+1 parallel redundant operation.

The ORing circuit is used inside the power module, and when any one of the power modules in the parallel fails, it will not affect the work of other power modules.

When used in parallel, the maximum load current cannot exceed the maximum output current of a single power supply module, otherwise the whole parallel power supply module will not start normally.

AC/DC1000W Enclosed Switching Power Supply

SLMF1000-20Bxx(-Q) Series

2.13.2 Current sharing

Method 1: current sharing bus and remote compensation lines are both connected.

For load line loss $< 200\text{mV}$, and the output voltage difference of each single module $< 50\text{mV}$, this type of connection is recommended to obtain a better line-end output voltage and current sharing effect.

The wiring method of the current sharing function is shown in the figure below:

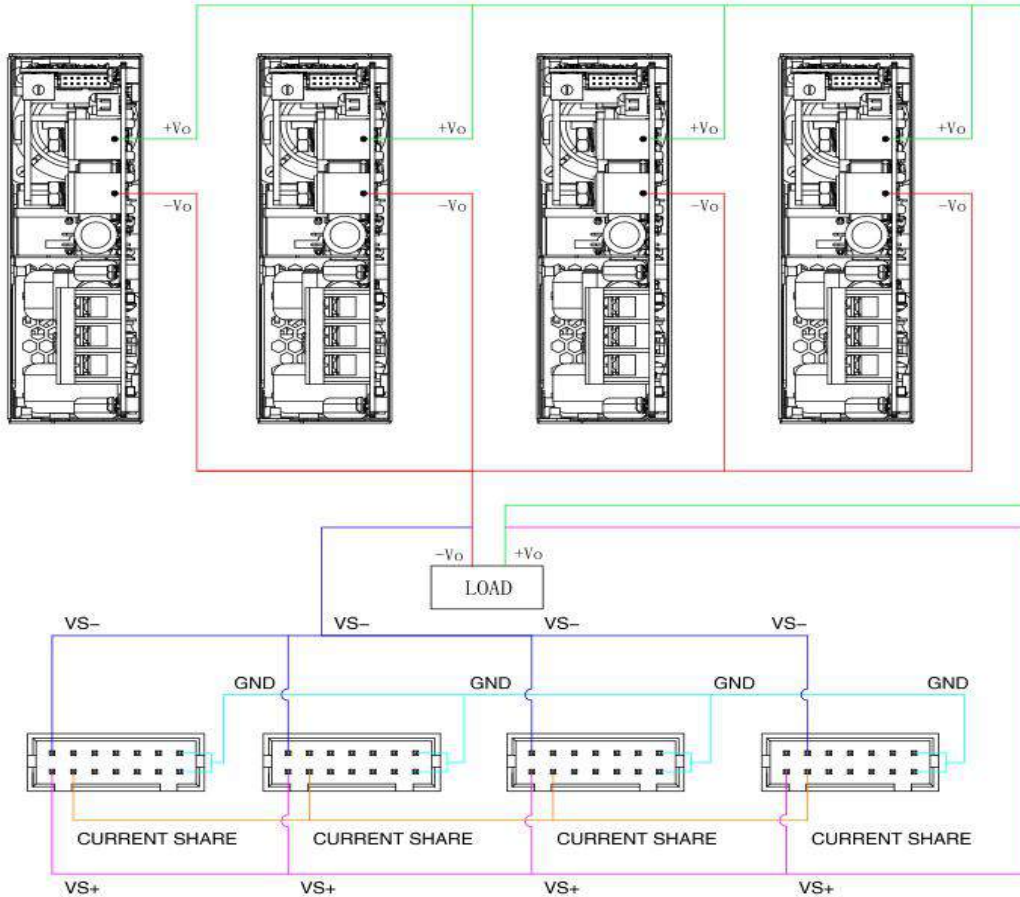

Method 2: Only the current sharing bus is connected, and the remote compensation is not connected.

For the load line loss $> 200\text{mV}$, or the output voltage difference of each single module cannot or does not need to be accurately adjusted to $< 50\text{mV}$, this type of connection is recommended to obtain a better current sharing effect of the parallel machine. In the same way, when the load loss is unknown or the current sharing fails to meet the specifications under the first connection method, it is recommended to replace it with this connected method.

The wiring method of the current sharing function is shown in the figure below:

AC/DC1000W Enclosed Switching Power Supply

SLMF1000-20Bxx(-Q) Series

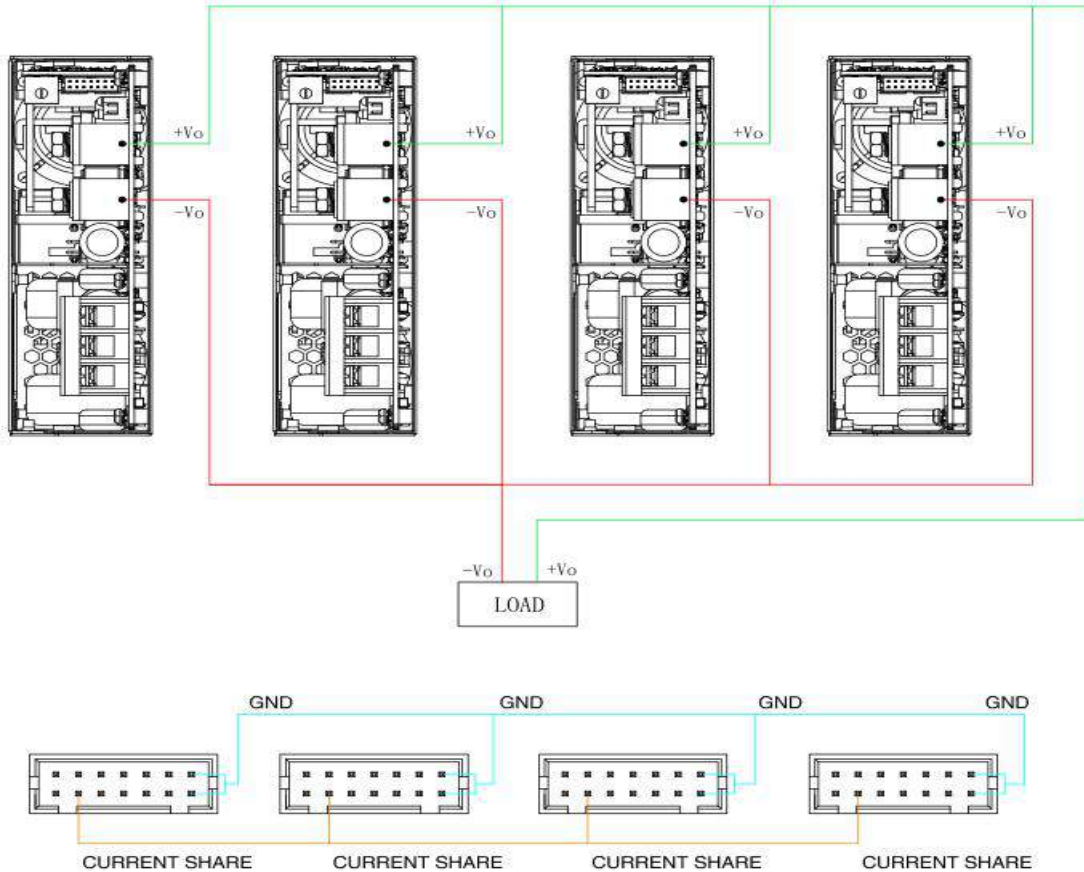

When using in parallel, the number of parallel modules cannot exceed 4.

When power modules work in parallel, there is an internal active current sharing circuit to ensure that the current between each module is balanced.

The active current sharing circuit adopts the automatic master-slave current sharing method. Each power module has a current sharing bus signal (CURRENT SHARE BUS). When working in parallel, the current sharing bus of all power modules must be connected together. The current-sharing bus signal is located at pin 2 of CN2.

The output voltage of each power module will affect the current sharing accuracy. The output voltage of the power module is the rated voltage $\pm 50\text{mV}$. In practical applications, if the output voltage value needs to be adjusted, the output voltage of all parallel power supply modules needs to be adjusted to the same voltage. The recommended voltage range: target voltage value $\pm 50\text{mV}$

After the output load of each power module is greater than 50% of the rated load, the current sharing accuracy should be $\pm 10\%$. The current sharing calculation formula is:

$$\text{Current sharing accuracy} = \frac{I_{o \max} - I_{o \min}}{I_{o \max}} * 100\%$$

$I_{o \max}$: the maximum output current value in parallel power supply modules.

$I_{o \min}$: the minimum output current value in parallel power supply modules.

AC/DC1000W Enclosed Switching Power Supply

SLMF1000-20Bxx(-Q) Series

2.14 I2C communication address

In the parallel system, if you need to identify the power module information, you need to set the I2C communication address for each parallel power module, and exchange data with the host computer through I2C. The setting of the communication address is determined by pins 9, 10 and 11 of the signal terminal CN2. When these three pins are short-circuited with pin 7 or 14 of CN2, it will be low level (L, voltage range: 0 ~ 1.31V). When disconnected, it is high level (H, voltage range: 1.99V~3.3V). The specific address number is shown in the table below:

ADDRESS 2	ADDRESS 1	ADDRESS 0	Address number
L	L	L	0
L	L	H	1
L	H	L	2
L	H	H	3
H	L	L	4
H	L	H	5
H	H	L	6
H	H	H	7

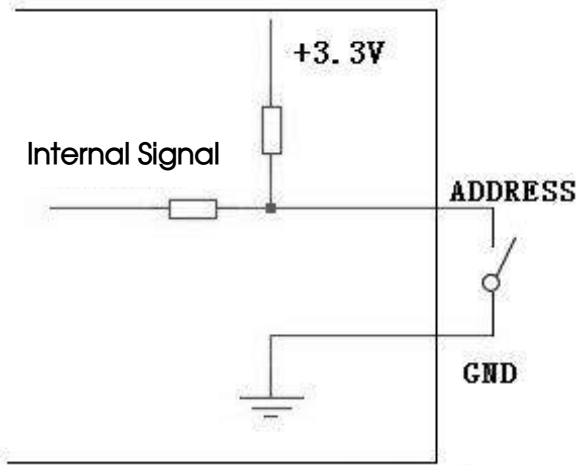

The internal pull-up resistance value of the power module is 10k Ω , and the external impedance can be matched according to the actual application to meet the high and low voltage range.

3. Installation requirements

3.1 Safety introduction

Warning

Risk of electric shock

During high voltage operating

- The power supply module is disconnected from the input DC or the AC power and placed for at least one minute before starting to operate it.
- When installing the input wire to the power module, please connect the ground terminal first, and then connect the L line and the N line.
- When removing the input wire, please remove the L wire and the N wire first, and then remove the ground wire.
- When disassembling, make sure that no objects fall into the power module.
- Pay attention to high temperature.
- After the power module is working in a high temperature environment, wait for its shell to cool down before operating.
- This product needs to be installed by professionals and needs to be used with other equipment.

3.2 Safety requirements

When installing, pay attention to the primary side and the protective ground, the creep distance and the electrical clearance of the primary side and the secondary side refer to EN60601-1.

AC/DC1000W Enclosed Switching Power Supply

SLMF1000-20Bxx(-Q) Series

3.3 Installation method

Standard mounting orientation:

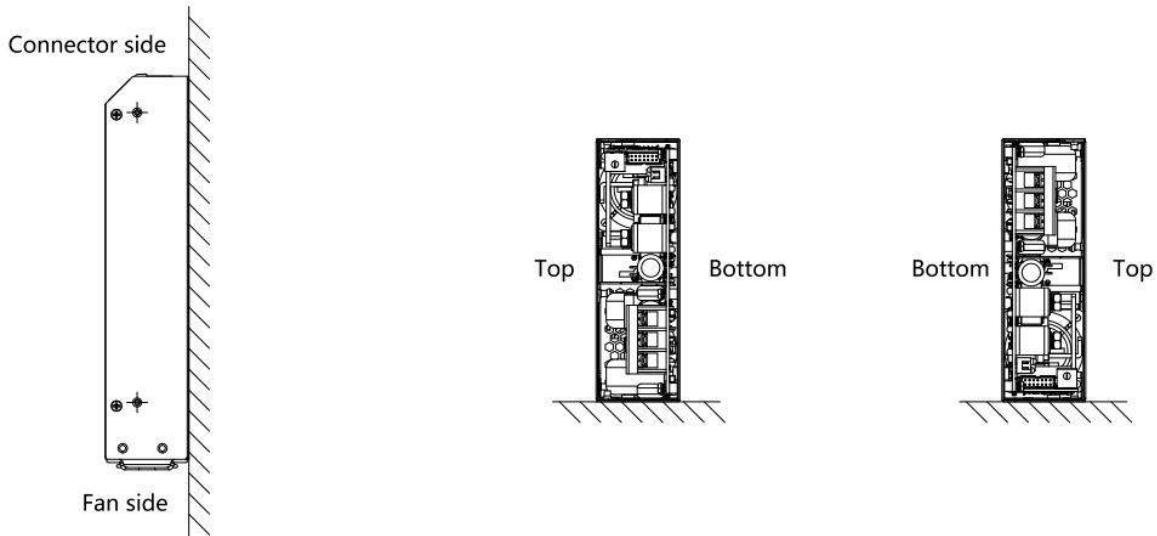
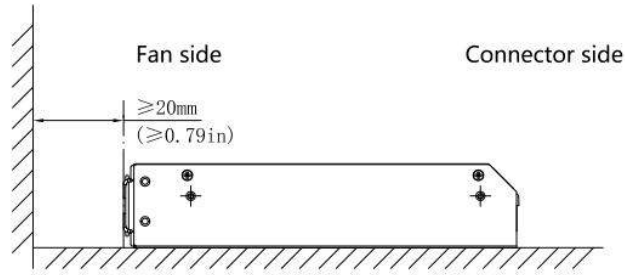

Position of mounting holes:

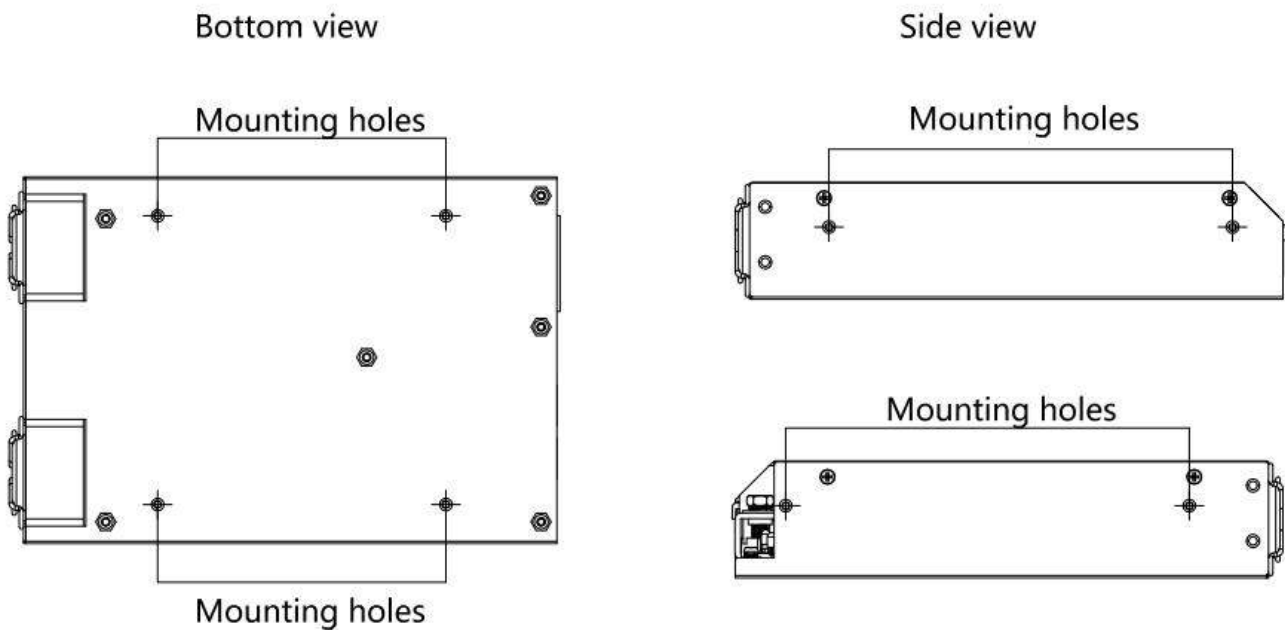

Note: The fan panel cannot be blocked by other objects, and a distance of at least 20mm must be maintained, otherwise it will affect the heat dissipation and performance of the power module.

4. Communication protocol

The SLMF1000-20Bxx series power modules support standard communication protocols and manage and monitor the power modules through I2C bus.

Command Code	Command Name	Access Type	Data Bytes	Data Format	Description
0x9A	PMB_MFR_MODEL	Block Read	32	ASCII	Product model
0x8B	PMB_READ_VOUT	Read Word	2	Direct	Main circuit output voltage (10mV)
0x8C	PMB_READ_IOUT	Read Word	2	Direct	Main output current (10mV)
0x96	PMB_READ_POUT	Read Word	2	Direct	Main output power (10mV)
0xC4	PMB_MFR_AUX_VOUT	Read Word	2	Direct	Auxiliary output voltage (10mV)
0xC5	PMB_MFR_AUX_IOUT	Read Word	2	Direct	Auxiliary output current (10mV)
0xC7	PMB_MFR_FAULT_BIT	Read Word	2	Bit Field	Fault status word

AC/DC1000W Enclosed Switching Power Supply

SLMF1000-20Bxx(-Q) Series

Describe Of Fault Status Through PMB_MFR_FAULT_BIT	
Bit segment	Description
BIT: 0	0: Fan 1 normal 1: Fan 1 fault
BIT: 1	0: Fan 2 normal 1: Fan 2 fault
BIT: 2	0: Auxiliary output normal 1: Auxiliary output abnormal
BIT: 3	0: No over-voltage in main circuit 1: Over-voltage in main circuit
BIT: 4	0: No under-voltage in main circuit 1: Under-voltage in main circuit
BIT: 5	0: No level 1 over-current in main circuit 1: Level 1 over-current in main circuit
BIT: 6	0: No level 2 over-current in main circuit 1: level 2 over-current in main circuit
BIT: 7	0: No level 1 over-load in main circuit 1: Level 1 over-load in main circuit
BIT: 8	0: No level 2 over-load in main circuit 1: Level 2 over-load in main circuit
BIT: 9	0: No level 3 over-load in main circuit 1: Level 3 over-load in main circuit
BIT: 10	0: Normal temperature 1: Over-temperature and over-load
BIT: 11	0: No short circuit in main circuit 1: Short circuit in main circuit
BIT: 12	0: No hardware over-voltage in main circuit 1: Main circuit hardware over-voltage fault
BIT: 13	0: No hardware under-voltage in main circuit 1: Main circuit hardware under-voltage fault
BIT: 14	0: Pre-charge normal 1: Pre-charge fault
BIT: 15	0: PFC soft start normal 1: PFC soft start fault