

DC/DC Converter

SK78Lxx-500R3 Series

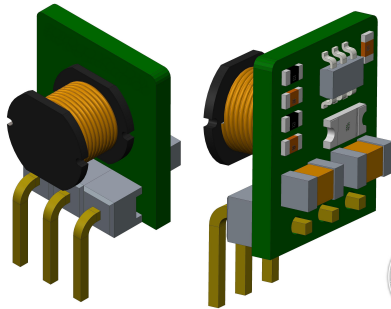

Wide input voltage , non-isolated & regulated single output



FEATURES

- Efficiency up to 93%
- Short circuit protection
- Ultra low no-load power consumption
- Open frame SIP package
- Operating temperature range: -40°C to +85°C

SK78Lxx-500R3 series are high efficiency switching regulators and ideal substitutes of SLM78xx series three-terminal linear regulators. The product is featured with high efficiency, low loss, short circuit protection and no heat sink requirement. They are widely used in industrial control, instrumentation, and electric power applications.

Selection Guide

Part Number	Input Voltage (VDC)	Output		Efficiency (Nominal Input Voltage) (% Min./Typ.) @Full Load	Max. Capacitive Load(μF)
	Nominal (Range)	Output Voltage (VDC)	Max. Output Current (mA)		
SK78L03-500R3	24 (4.75-36)	3.3	500	78/81	680
SK78L05-500R3	24 (6.5-36)	5.0	500	82/85	680
	12 (7-31)	-5.0	-300	78/81	330
SK78L12-500R3	24 (15-36)	12	500	89/92	680
	12 (8-24)	-12	-150	82/85	330
SK78L15-500R3	24 (19-36)	15	500	90/93	680
	12 (8-21)	-15	-150	82/85	330

Note: For input voltage higher than 30 VDC, an 22μF/50V input capacitor is required.

Input Specifications

Item	Operating Conditions	Min.	Typ.	Max.	Unit
No-load Input Current		--	0.2	1.5	mA
Reverse Polarity Input		Forbidden			
Input Filter		Capacitor filter			

Output Specifications

Item	Operating Conditions	Min.	Typ.	Max.	Unit	
Output Voltage Accuracy	Full load, input voltage range	SK78L03-500R3	--	±2	±4	%
		Others	--	±2	±3	
Line Regulation	Input voltage range	--	±0.2	±0.4	%	
Load Regulation	10%-100% load	--	±0.4	±0.6		
Ripple & Noise*	20MHz bandwidth, Vin=24VDC, 10% -100% load	--	20	75		mVp-p
Temperature Drift Coefficient	Operating temperature -40°C ~ +85°C	--	--	±0.03	%/°C	
Transient response deviation	Nominal input, 25% load step change	--	55	250	mV	
Transient recovery time		--	0.5	2	ms	

DC/DC Converter

SK78Lxx-500R3 Series

Over-heat protection	Internal IC junction	--	170	--	°C
Output short circuit protection		Continuous, self-recovery			
Note: *1. Ripple and noise tested with "parallel cable" method, please refer to <i>DC-DC Converter Application Notes</i> for specific operation methods;					
*2. With the load lower than 10%, maximum ripple and noise will be 150mVp-p.					

General Specifications

Item	Operating Conditions	Min.	Typ.	Max.	
Operating Temperature	Derating if the temperature $\geq 71^\circ\text{C}$ (see Fig. 1)	-40	--	85	°C
Storage Temperature		-55	--	125	
Pin Welding Resistance Temperature	Welding time: 10s (Max.)	--	--	260	
Storage Humidity	Non-condensing	5	--	95	%RH
Switching Frequency	Full load, input voltage range	550	--	850	KHz
MTBF	MIL-HDBK-217F@25°C	2000	--	--	K hours

Physical Specifications

Package Dimensions	11.00*10.00*7.20 mm
Weight	1.0g (Typ.)
Cooling Method	Free air convection

EMC Specifications

EMI	Conducted Disturbance	CISPR22/EN55022	CLASS B (see Fig. 5-② for recommended circuit)	
	Radiated Emission	CISPR22/EN55022	CLASS B (see Fig. 5-② for recommended circuit)	
EMS	Electrostatic Discharge	IEC/EN 61000-4-2	Contact $\pm 4\text{KV}$	perf. Criteria B
	Radiation Immunity	IEC/EN 61000-4-3	10V/m	perf. Criteria A
	EFT	IEC/EN 61000-4-4	$\pm 1\text{KV}$ (see Fig. 5-① for recommended circuit)	perf. Criteria B
	Conducted Disturbance Immunity	IEC/EN 61000-4-6	3Vr.m.s	perf. Criteria A
	Voltage dip, drop and short interruption	IEC/EN 61000-4-29	0%-70%	perf. Criteria B

Product Characteristic Curve

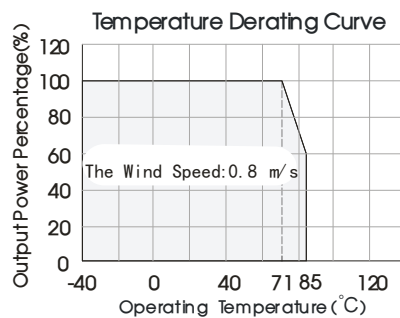
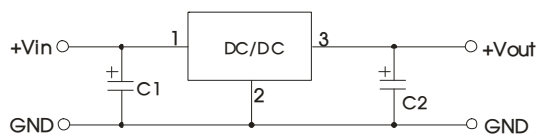

Fig. 1

Design Reference

1. Typical application circuit



Positive output application circuit

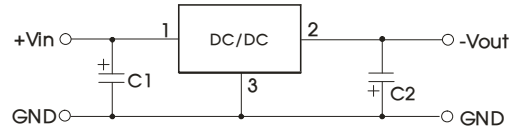

Negative output application circuit

Fig. 2 Typical application circuit

DC/DC Converter

SK78Lxx-500R3 Series

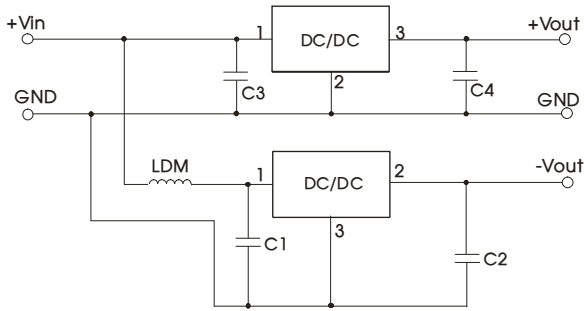

Fig. 3 Positive and Negative output paralleling application circuit

Note:

1. C1 and C2 are required and should be connected close to the pin terminal of the module.
2. The capacitance of C1 and C2 refer to Sheet 1, it can be increased properly if required, and tantalum or low ESR electrolytic capacitors may also suffice.
3. When the products used as the circuit like figure 3, an inductor named as LDM up to 10 μ H is recommended in the circuit to reduce the mutual interference.
4. Cannot be used in parallel for output and hot swap.
5. Operation under no load will not damage these devices, however they may not meet all specifications. In order to ensure the converter can work reliably with high efficiency, please parallel a resistor on the output side (The sum of the efficient power and resistor consumption power is not less than 10%).

To reduce the output ripple furtherly, it is suggested to connect a "LC" filter at the output terminal, and recommended value of L is 10 μ H-47 μ H.

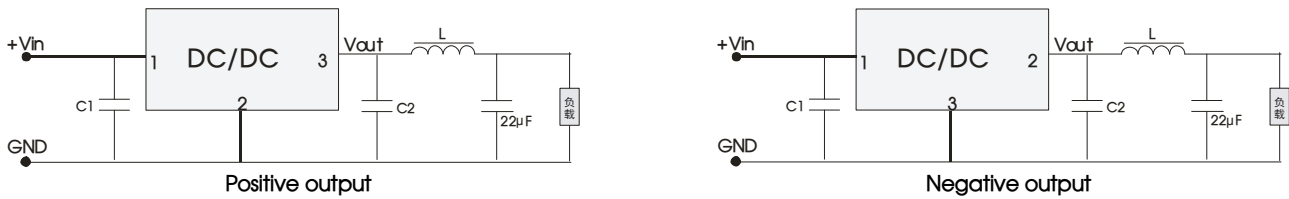

Fig. 4 "LC" filter application circuit

2. EMC solution-recommended circuit

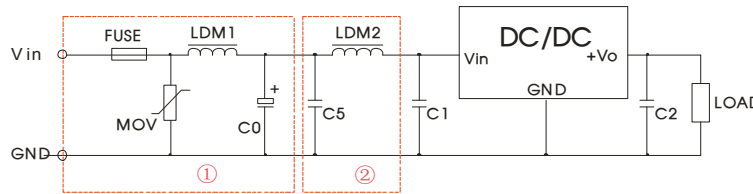

Fig. 5 EMC recommended circuit

FUSE	MOV	LDM1	C0	C1/C2	C5	LDM2
Selected based on the actual input current from the customer	S10K35	82 μ H	680 μ F /50V	Refer to Sheet 1	4.7 μ F /50V	12 μ H

Note: Part ① in the Fig. 5 is for EMS test, part ② is for EMI filtering; parts ① and ② can be added based on actual requirement.

DC/DC Converter

SK78Lxx-500R3 Series

Dimensions and Recommended Layout

THIRD ANGLE PROJECTION 

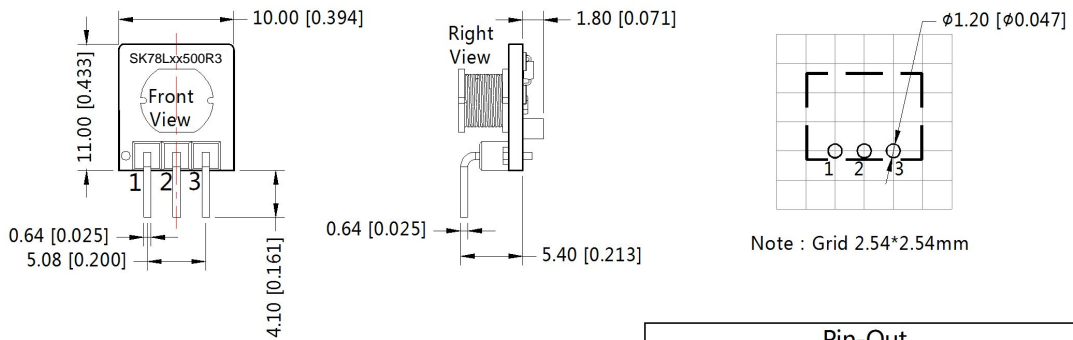

Note:
 Unit :mm[inch]
 Pin diameter tolerances :±0.10[±0.004]
 General tolerances:±0.50[±0.020]

Pin-Out		
Pin	Positive Output	Negative Output
1	V _{in}	V _{in}
2	GND	-V _o
3	+V _o	GND

Notes:

1. Packing information please refer to Product Packing Information. Packing bag number: 58010116;
2. The max. capacitive load should be tested within the input voltage range and under full load conditions;
3. Without any special statement, all indexes are only specific to positive output application;
4. Unless otherwise specified, data in this datasheet should be tested under the conditions of T_a=25°C, humidity<75% when inputting nominal voltage and outputting rated load;
5. All index testing methods in this datasheet are based on our Company's corporate standards;
6. The performance indexes of the product models listed in this manual are as above, but some indexes of non-standard model products will exceed the above-mentioned requirements, and please directly contact with our technician for specific information;
7. Specifications of this product are subject to changes without prior notice.