

1W Isolated DC-DC converter
Fixed input voltage, unregulated single output

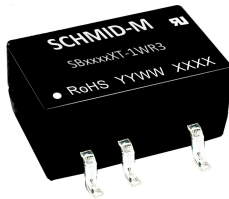

UL **CE** **CB** Patent Protection **RoHS**

FEATURES

- Continuous short-circuit protection
- No-load input current as low as 8mA
- Operating ambient temperature range: -40°C to +105°C
- High efficiency up to 85%
- Compact SMD package
- I/O isolation test voltage: 1.5k VDC
- Industry standard pin-out
- IEC62368, UL62368, EN62368 approved

SB_XT-1WR3 series are specially designed for applications where an isolated voltage is required in a distributed power supply system. They are suitable for: pure digital circuits, low frequency analog circuits, relay-driven circuits and data switching circuits.

Selection Guide

Certification	Part No.	Input Voltage (VDC)	Output		Full Load Efficiency (%) Min./Typ.	Capacitive Load(μF) Max.
		Nominal (Range)	Voltage (VDC)	Current (mA) Max./Min.		
UL/CE/CB	SB1205XT-1WR3	12 (10.8-13.2)	5	200/20	78/82	2400
	SB1209XT-1WR3		9	111/12	79/83	1000
	SB1212XT-1WR3		12	84/9	79/83	560
	SB1215XT-1WR3		15	67/7	79/83	560
	SB1224XT-1WR3		24	42/4	81/85	220
	SB1505XT-1WR3		15 (13.5-16.5)	5	200/20	78/82
SB1509XT-1WR3	9	111/12		78/82	1000	
SB1515XT-1WR3	15	67/7		79/83	560	
UL/CE/CB	SB2405XT-1WR3	24 (21.6-26.4)	5	200/20	74/80	2400
	SB2409XT-1WR3		9	111/12	74/80	1000
	SB2412XT-1WR3		12	84/9	74/80	560
	SB2415XT-1WR3		15	67/7	74/80	560
	SB2424XT-1WR3		24	42/4	74/80	220
	SB2405XT-1WR3		5	200/20	74/80	2400

Input Specifications

Item	Operating Conditions		Min.	Typ.	Max.	Unit	
Input Current (full load / no-load)	12VDC input	5VDC output	--	102/8	107/--	mA	
		9VDC/12VDC/15VDC output	--	101/8	106/--		
		24VDC output	--	99/8	103/--		
	15VDC input	5VDC/9VDC output	--	82/8	86/--		
		15VDC output	--	81/8	85/--		
	24VDC input	5VDC output	--	53/8	57/--		
		9VDC/12VDC/15VDC output	--	51/8	55/--		
	24VDC output	--	53/8	57/--			
Reflected Ripple Current*			--	15	--		
Surge Voltage(1sec. max.)	12VDC input			-0.7	--	18	VDC
	15VDC input			-0.7	--	21	
	24VDC input			-0.7	--	30	
Input Filter			Capacitance filter				

DC/DC Converter

SB_XT-1WR3 Series

Hot Plug		Unavailable
Note: * Reflected ripple current testing method please see DC-DC Converter Application Notes for specific operation.		

Output Specifications

Item	Operating Conditions	Min.	Typ.	Max.	Unit	
Voltage Accuracy		See output regulation curves (Fig. 1)				
Linear Regulation	Input voltage change: $\pm 1\%$	--	--	1.2	--	
Load Regulation	10%-100% load	5VDC output	--	5	15	%
		9VDC output	--	3	10	
		12VDC output	--	3	10	
		15VDC output	--	3	10	
		24VDC output	--	2	10	
Ripple & Noise*	20MHz bandwidth	5VDC/9VDC/12VDC/15V DC output	---	30	75	mVp-p
		24VDC output	---	50	100	
Temperature Coefficient	Full load	--	± 0.02	--	%/°C	
Short-Circuit Protection		Continuous, self-recovery				

Notes: * The "parallel cable" method is used for ripple and noise test, please refer to *DC-DC Converter Application Notes* for specific information.

General Specifications

Item	Operating Conditions	Min.	Typ.	Max.	Unit
Isolation	Input-output electric strength test for 1 minute with a leakage current of 1mA max.	1500	--	--	VDC
Insulation Resistance	Input-output resistance at 500VDC	1000	--	--	MΩ
Isolation Capacitance	Input-output capacitance at 100kHz/0.1V	--	20	--	pF
Operating Temperature	Derating when operating temperature $\geq 100^\circ\text{C}$, (see Fig. 2)	-40	--	105	°C
Storage Temperature		-55	--	125	
Case Temperature Rise	Ta=25°C	--	25	--	
Storage Humidity	Non-condensing	5	--	95	%RH
Reflow Soldering Temperature*		Peak temp. $\leq 245^\circ\text{C}$, maximum duration time $\leq 60\text{s}$ over 217°C			
Vibration		10-150Hz, 5G, 0.75mm. along X, Y and Z			
Switching Frequency	Full load, nominal input voltage	--	260	--	kHz
MTBF	MIL-HDBK-217F@25°C	3500	--	--	k hours
Moisture Sensitivity Level (MSL)	IPC/JEDEC J-STD-020D.1	Level 1			

Note: *For actual application, please refer to IPC/JEDEC J-STD-020D.1.

Mechanical Specifications

Case Material	Black plastic; flame-retardant and heat-resistant (UL94 V-0)
Dimensions	13.20 x 11.40 x 7.25 mm
Weight	1.4g(Typ.)
Cooling Method	Free air convection

Electromagnetic Compatibility (EMC)

Emissions	CE	CISPR32/EN55032	CLASS B
	RE	CISPR32/EN55032	CLASS B
Immunity	ESD	IEC/EN61000-4-2	Air $\pm 8\text{kV}$, Contact $\pm 6\text{kV}$ perf. Criteria B

Note: Refer to Fig.4 for recommended circuit test.

DC/DC Converter

SB_XT-1WR3 Series

Typical Performance Curves

Output Regulation Curve

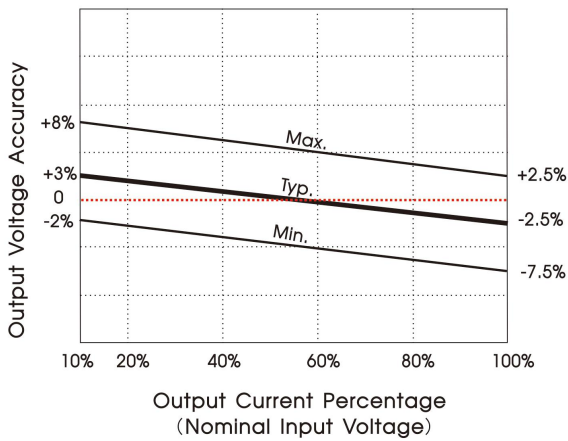

Fig. 1

Temperature Derating Curve

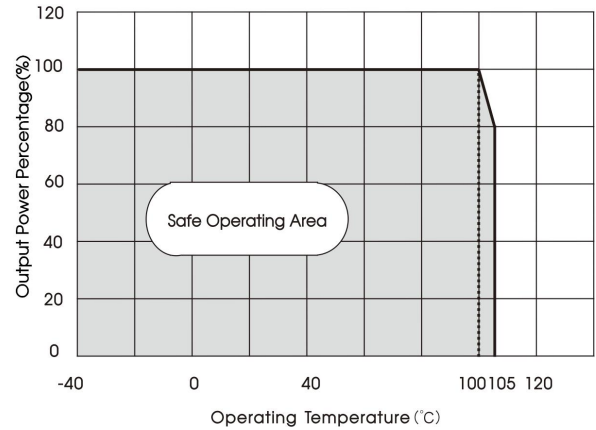
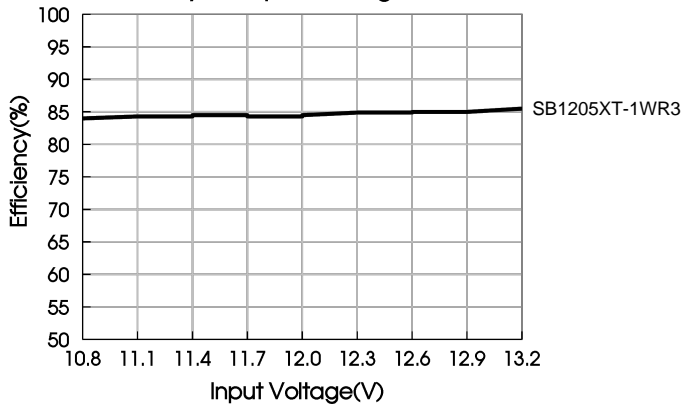
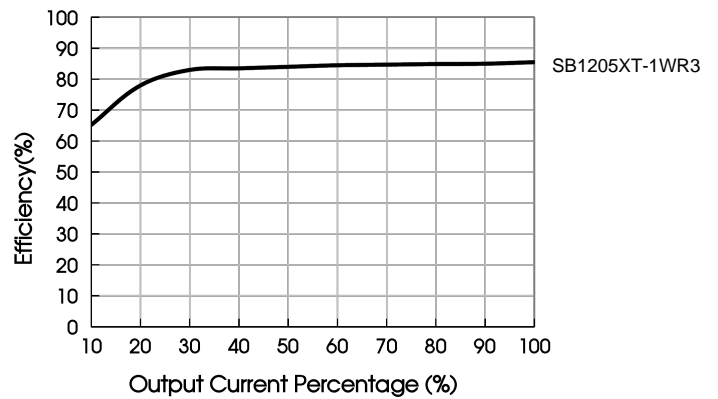

Fig. 2

Efficiency Vs Input Voltage (Full Load)



Efficiency Vs Output Load (Vin=12V)



Efficiency Vs Input Voltage (Full Load)

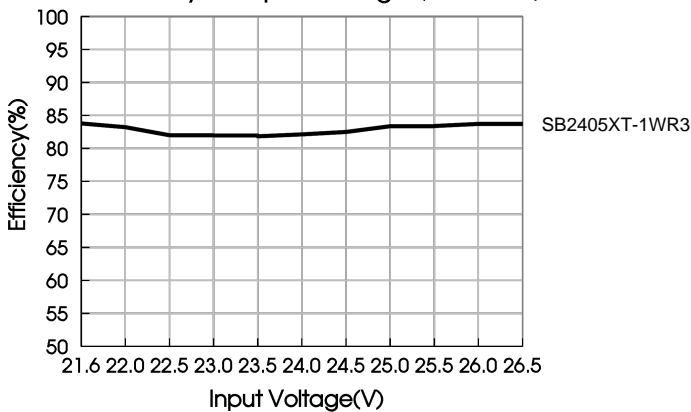

Efficiency Vs Output Load (Vin=24V)

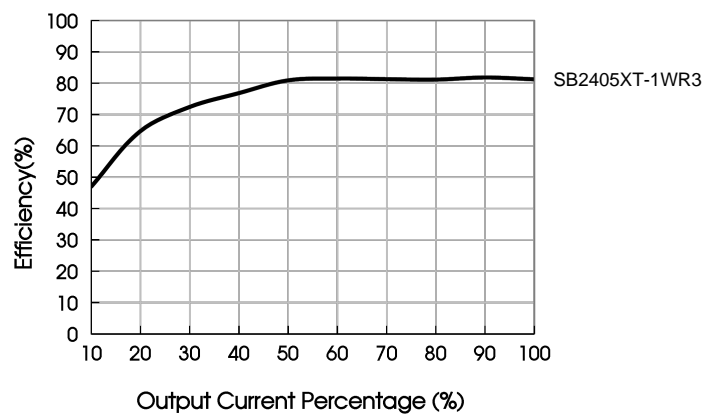

Design Reference

1. Typical application

Input and/or output ripple can be further reduced, by connecting a filter capacitor from the input and/or output terminals to ground as shown in Fig.3.

Choosing suitable filter capacitor values is very important for a smooth operation of the modules, particularly to avoid start-up problems caused by capacitor values that are too high. For recommended input and output capacitor values refer to Table 1.

DC/DC Converter

SB_XT-1WR3 Series

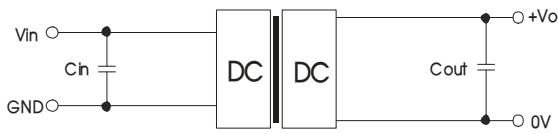

Fig.3

Table 1: Recommended input and output capacitor values

Vin	Cin	Vo	Cout
12VDC	2.2μF/25V	5VDC	10μF/16V
15VDC	2.2μF/25V	9VDC	2.2μF/16V
24VDC	1μF/50V	12VDC	2.2μF/25V
--	--	15VDC	1μF/25V
--	--	24VDC	1μF/50V

2. EMC compliance circuit

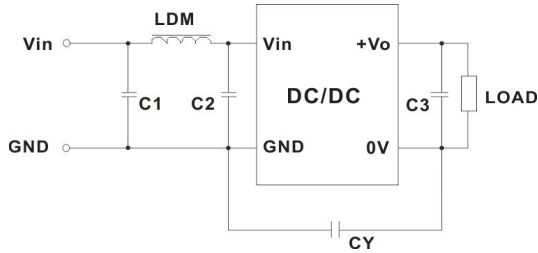
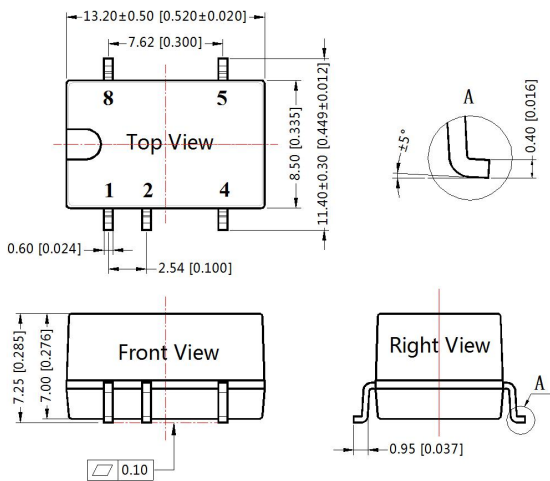

Fig.4

Table 2: EMC recommended circuit value table

EMI	C1	4.7μF /50V
	C2	4.7μF /50V
	CY	270pF/2kV
	C3	Refer to the Cout in table 1
	LDM	6.8μH

Dimensions and Recommended Layout



Note:
 Unit: mm[inch]
 Pin section tolerances: ±0.10[±0.004]
 General tolerances: ±0.25[±0.010]

THIRD ANGLE PROJECTION

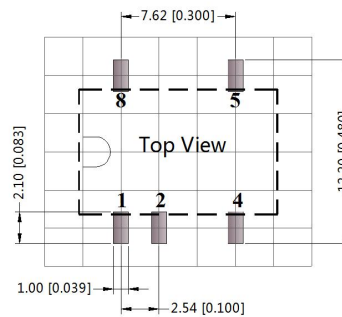

Note: Grid 2.54*2.54mm

Pin-Out	
Pin	Function
1	GND
2	Vin
4	0V
5	+Vo
8	NC

NC: Pin to be isolated from circuitry

DC/DC Converter

SB_XT-1WR3 Series

Tape and Reel Info

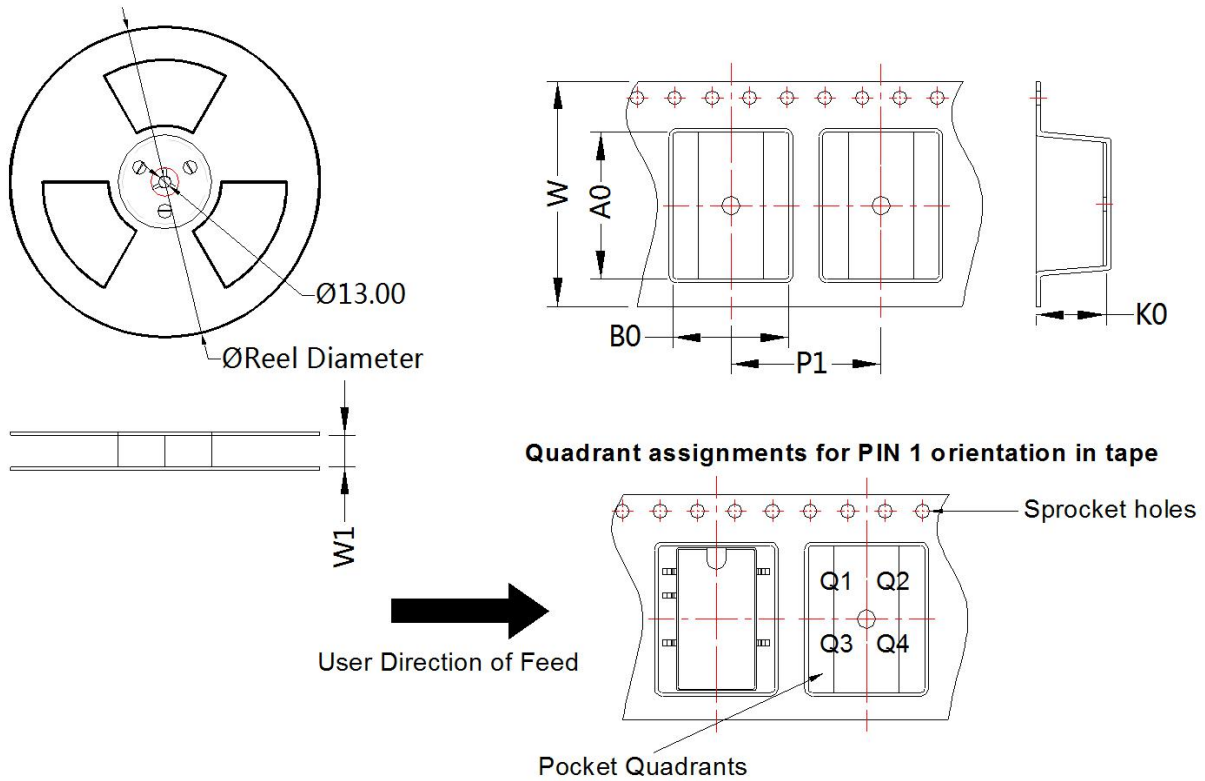

Device	Package Type	Pin	SPQ	Reel Diameter (mm)	Reel Width W1 (mm)	A0 (mm)	B0 (mm)	K0 (mm)	P1 (mm)	W (mm)	Pin1 Quadrant
SB_XT-1WR3	SMD	5	500	330.0	24.5	13.4	11.7	7.5	16.0	24.0	Q1

Notes:

1. If the product is not operated within the required load range, the product performance cannot be guaranteed to comply with all parameters in the datasheet;
2. The maximum capacitive load offered were tested at input voltage range and full load;
3. Unless otherwise specified, parameters in this datasheet were measured under the conditions of $T_a=25^{\circ}\text{C}$, humidity<75%RH with nominal input voltage and rated output load;
4. All index testing methods in this datasheet are based on our company corporate standards;
5. We can provide product customization service, please contact our technicians directly for specific information;
6. Products are related to laws and regulations: see "Features" and "EMC";
7. Our products shall be classified according to ISO14001 and related environmental laws and regulations, and shall be handled by qualified units.