

FEATURES :

- 7PIN SIP Package
- No-load input current as low as 5mA
- Continuous short-circuit protection
- High Efficiency up to 89%
- Unregulated Output Types
- 1.5KVDC ~ 6KVDC Isolation
- Operating Temperature:-40°C TO +105°C
- Industry Standard Pinout
- Design refer to IEC62368, UL62368, EN62368

DC-DC Converter S12DC-2W SERIES

2Watt

1.5~6KV Isolated
Single & Dual Output
SIP7

Specifications typical at TA=25°C, nominal input voltage and rated output current unless otherwise specified

Part Number	Output Voltage	Output Current	Efficiency	Capacitive Load(μF)
	Vdc	mA	%TYP	Max.
S12DC-12S05NP2 ^(H3)	5	400	85	2400
S12DC-12S09NP2 ^(H3)	9	223	87	820
S12DC-12S12NP2 ^(H3)	12	167	87	470
S12DC-12S15NP2 ^(H3)	15	133	88	220
S12DC-12S24NP2 ^(H3)	24	84	89	100
S12DC-12D05NP2 ^(H3)	±5	±200	82	±1200
S12DC-12D09NP2 ^(H3)	±9	±112	85	±330
S12DC-12D12NP2 ^(H3)	±12	±84	87	±330
S12DC-12D15NP2 ^(H3)	±15	±67	88	±100
S12DC-12D24NP2 ^(H3)	±24	±42	89	±47
S12DC-15S05NP2 ^(H3)	5	400	85	2400
S12DC-15S09NP2 ^(H3)	9	223	87	820
S12DC-15S12NP2 ^(H3)	12	167	87	470
S12DC-15S15NP2 ^(H3)	15	133	88	220
S12DC-15S24NP2 ^(H3)	24	84	89	100
S12DC-15D05NP2 ^(H3)	±5	±200	82	±1200
S12DC-15D09NP2 ^(H3)	±9	±112	85	±330
S12DC-15D12NP2 ^(H3)	±12	±84	87	±330
S12DC-15D15NP2 ^(H3)	±15	±67	88	±100
S12DC-15D24NP2 ^(H3)	±24	±42	89	±47
S12DC-24S05NP2 ^(H3)	5	400	85	2400
S12DC-24S09NP2 ^(H3)	9	223	87	820
S12DC-24S12NP2 ^(H3)	12	167	87	470
S12DC-24S15NP2 ^(H3)	15	133	88	220
S12DC-24S24NP2 ^(H3)	24	84	89	100
S12DC-24D05NP2 ^(H3)	±5	±200	82	±1200
S12DC-24D09NP2 ^(H3)	±9	±112	85	±330
S12DC-24D12NP2 ^(H3)	±12	±84	87	±330
S12DC-24D15NP2 ^(H3)	±15	±67	88	±100
S12DC-24D24NP2 ^(H3)	±24	±42	89	±47

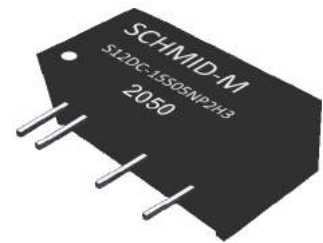

Temperature Derating Graph

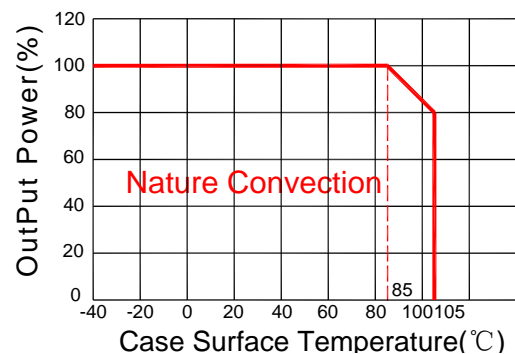

Note:

1:No suffix is standard isolation (1.5KVDC) e.g, S12DC-12S05NP2 ,
*add suffix "H3" for 3KVDC isolation, *add suffix "H4" for 4KVDC isolation,
*add suffix "H5" for 5.2KVDC isolation, *add suffix "H6" for 6KVDC isolation,
e.g, S12DC-12S05NP2H3, S12DC-24D24NP2H6.

Input Specifications

Parameters	Conditions	Min	Typ	Max	Units
Voltage Range	V _{o,lo} Nom		±10		%
Filter	Capacitor				

Output Specifications

Parameters	Conditions	Min	Typ	Max	Units
Voltage Tolerance	100% full load			±5	%
Short Circuit Protection	Continuous				
Line Regulation	For 1.0% OF Vin		1.2		%
Load Regulation	5V (10% To 100% F.L)		8	15	%
	9V (10% To 100% F.L)		6	10	%
	12V (10% To 100% F.L)		5	10	%
	15V (10% To 100% F.L)		4	10	%
	24V (10% To 100% F.L)		3	10	%
Ripple & Noise	BW=DC To 20MHz		75	150	mVp-p

General Specifications

Parameters	Conditions	Min	Typ	Max	Units
Isolation Resistance	500Vdc	1000			MΩ
Isolation Capacitance	Input-output, 100KHz/0.1V		20		pF
Switching Frequency	Full load, nominal input		250		KHz
Operation Temperature		-40		+105	°C
Storage Temperature		-55		+125	°C
Humidity	Non Condensing			95	%
Cooling	Free air Convection				
Case material	DAP				
MTBF	MIL-HDBK-217F@25°C	3500000			Hours
Weight			2.1		g
Dimensions		19.5x6.0x10.0			mm

Part Number

S12DC - 15 S 05 N P 2 H3
 A B C D E F G H

A:Series
 B:Input Voltage
 C:Single(S)/Dual(D)Output
 D:Output Voltage
 E:Unregulated(N)
 F:Protection
 G:Output Power
 H:Isolation Voltage

Tolerance Envelope Graph

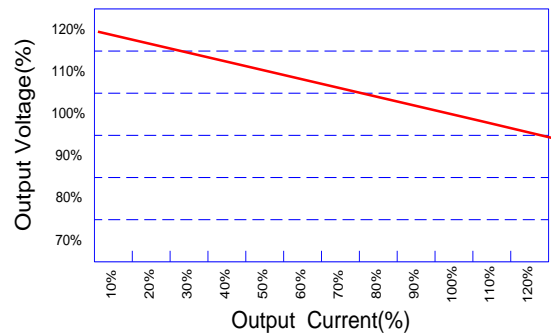

Electromagnetic Compatibility (EMC)

EMI	CE	CISPR32/EN55032 CLASS B (see Fig. 1 for recommended circuit)
	RE	CISPR32/EN55032 CLASS B (see Fig. 1 for recommended circuit)
EMS	ESD	IEC/EN61000-4-2 Air ±8kV , Contact ±4kV perf. Criteria B

Packaging

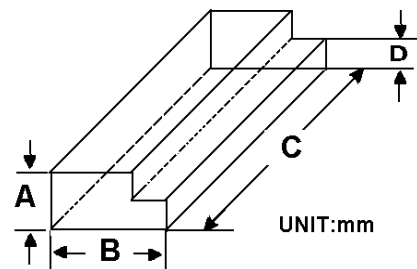

Size(mm)			
A	B	C	D
9.5	16.5	522	5.0

Recommended Test Circuit

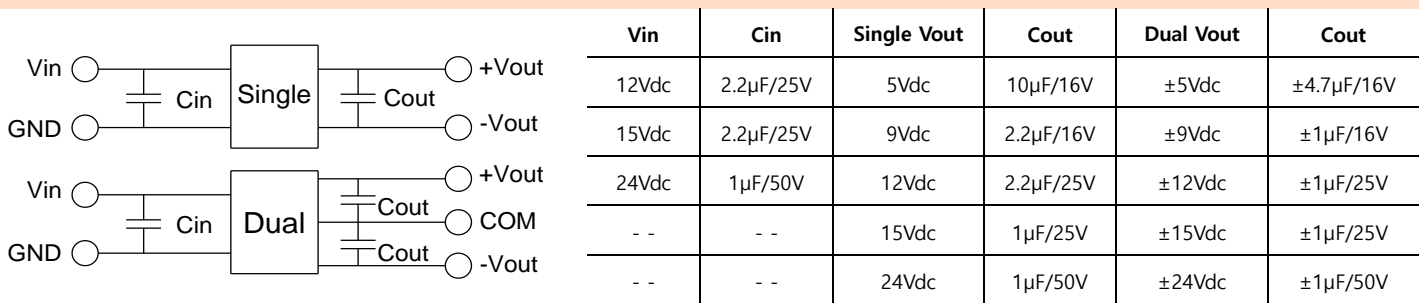

EMC (CLASS B) compliance circuit

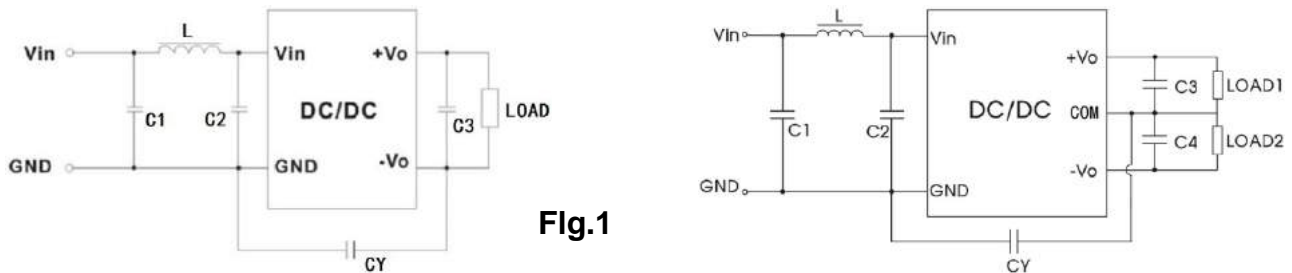

EMC recommended circuit value table

EMC recommended circuit value table		
EMI	C1	4.7μF /50V
	C2	4.7μF /50V
	CY	1nF/4kV
	C3	Recommended Test Circuit
	L	6.8μH

Markings and Dimensions

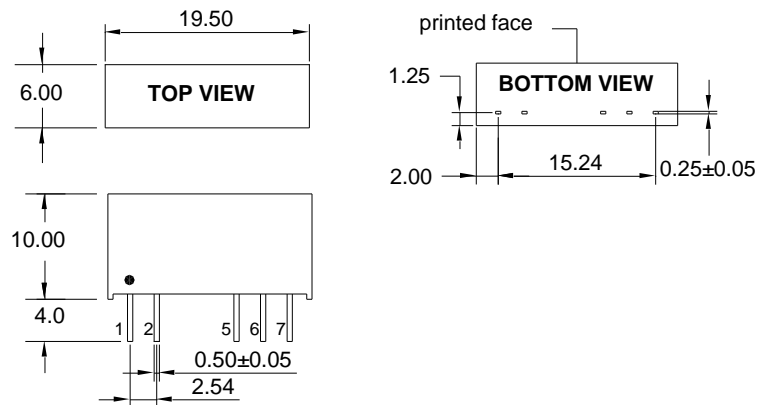

UNIT:mm Unless otherwise specified,all tolerances are ±0.25

PIN Connection

PIN	1	2	5	6	7
Single	+Vin	-Vin	-Vout	No Pin	+Vout
Dual	+Vin	-Vin	-Vout	Com	+Vout