

# SPECIFICATION FOR APPROVAL

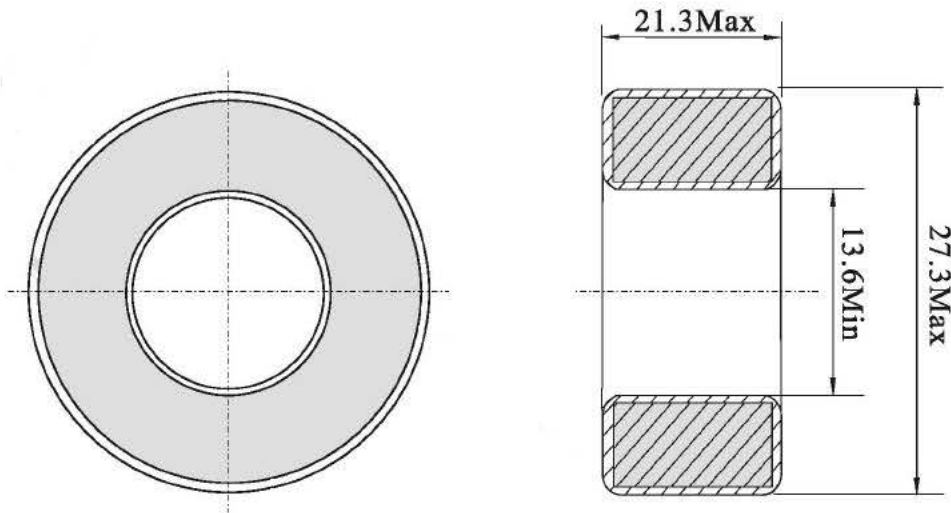

CUSTOMER		PART NO:	P3 T26X14.5X20C
DATE	2020/04/20	TEMPERATURE	25°C
HUMIDITY	60%		

## 1. DIMENSIONS: (mm)



## 2. ELECTRICAL CHARACTERISTICS

AL nH/N <sup>2</sup>	C <sub>i</sub> /A mm <sup>-1</sup>	Le mm	Ae mm <sup>2</sup>	Ve mm <sup>3</sup>	
5250 ± 30%	0.55	63.58	115	7312.2	
TEST CONDITIONS	AL: F=1.0KHz U=0.3V T=23°C ± 3°C N=100Ts Pg: F=100KHz B=200mT T=100°C				
TESTING EQUIPMENT	HP4284A CH-258				

Initial permeability: 2300 ± 25%

**Patron**  
Passive Elektronik