

Light dependent resistors

Data Sheet

NORP12
NSL19-M51

Two cadmium sulphide (cdS) photoconductive cells with spectral responses similar to that of the human eye. The cell resistance falls with increasing light intensity. Applications include smoke detection, automatic lighting control, batch counting and burglar alarm systems.

Guide to source illuminations

Light source	Illumination (Lux)
Moonlight	0.1
60W bulb at 1m	50
1W MES bulb at 0.1m	100
Fluorescent lighting	500
Bright sunlight	30,000

Circuit symbol

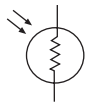

Light memory characteristics

Light dependent resistors have a particular property in that they remember the lighting conditions in which they have been stored. This memory effect can be minimised by storing the LDRs in light prior to use. Light storage reduces equilibrium time to reach steady resistance values.

NORP12

Absolute maximum ratings

Voltage, ac or dc peak	320V
Current	75mA
Power dissipation at 30°C	250mW
Operating temperature range	-60°C to +75°C

Electrical characteristics

$T_A = 25^\circ\text{C}$. 2854°K tungsten light source

Parameter	Conditions	Min.	Typ.	Max.	Units
Cell resistance	1000 lux	-	400	-	Ω
	10 lux	-	9	-	k Ω
Dark resistance	-	1.0	-	-	M Ω
Dark capacitance	-	-	3.5	-	pF
Rise time 1	1000 lux	-	2.8	-	ms
	10 lux	-	18	-	ms
Fall time 2	1000 lux	-	48	-	ms
	10 lux	-	120	-	ms

1. Dark to 110% R_L

2. To 10% R_L

R_L = photocell resistance under given illumination.

Features

- Wide spectral response
- Low cost
- Wide ambient temperature range.

Dimensions

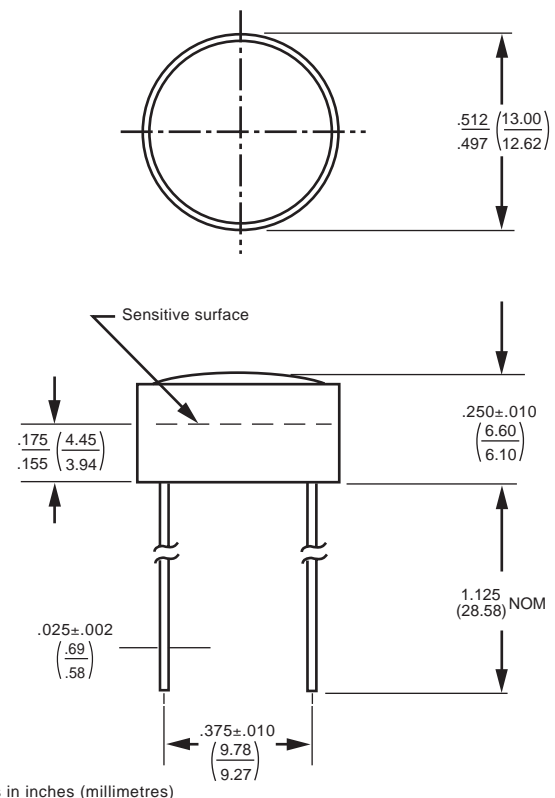

Figure 1 Power dissipation derating

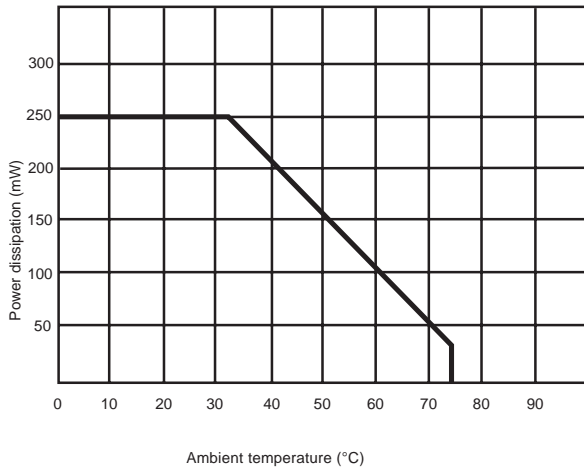
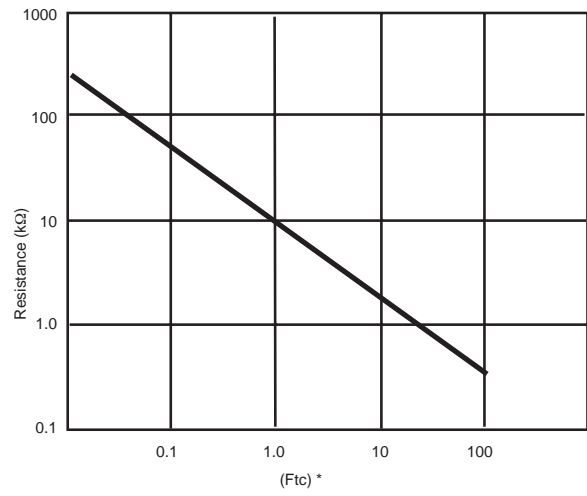
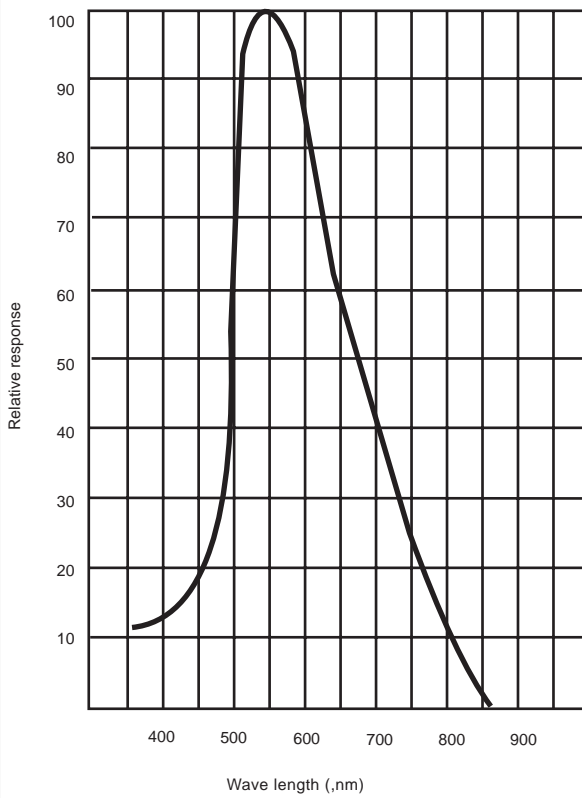

Figure 3 Resistance as a function of illumination



*1Ftc=10.764 lumens

Figure 2 Spectral response



Absolute maximum ratings

Voltage, ac or dc peak _____ 100V
 Current _____ 5mA
 Power dissipation at 25°C _____ 50mW*
 Operating temperature range _____ -25°C +75°C

*Derate linearly from 50mW at 25°C to 0W at 75°C.

Electrical characteristics

Parameter	Conditions	Min.	Typ.	Max.	Units
Cell resistance	10 lux	20	-	100	kΩ
	100 lux	-	5	-	kΩ
Dark resistance	10 lux after 10 sec	20	-	-	MΩ
Spectral response	-	-	550	-	nm
Rise time	10ftc	-	45	-	ms
Fall time	10ftc	-	55	-	ms

Figure 4 Resistance as a function illumination

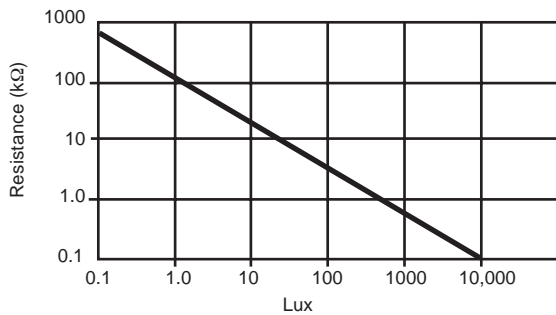

Dimensions

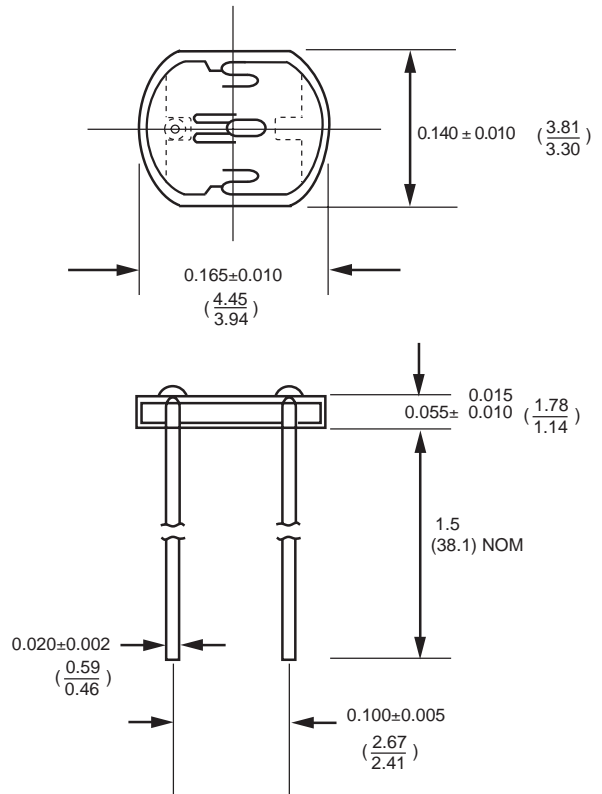
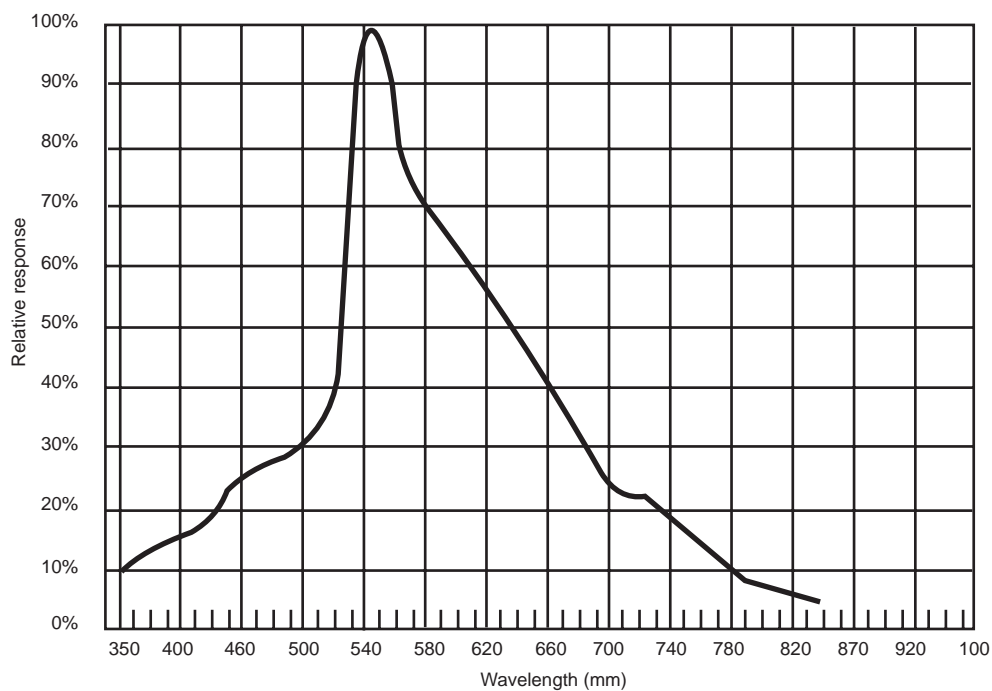
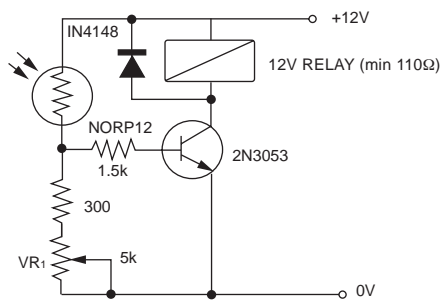

Figure 5 Spectral response



Typical application circuits

Figure 6 Sensitive light operated relay



Relay energised when light level increases above the level set by VR₁

Figure 7 Light interruption detector

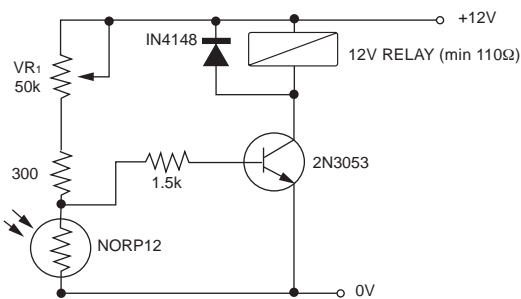

As Figure 6 relay energised when light level drops below the level set by VR₁

Figure 8 Automatic light circuit

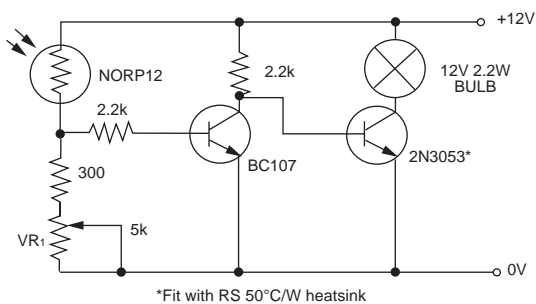

*Fit with RS 50°C/W heatsink

Adjust turn-on point with VR₁

Figure 9 Logarithmic law photographic light meter

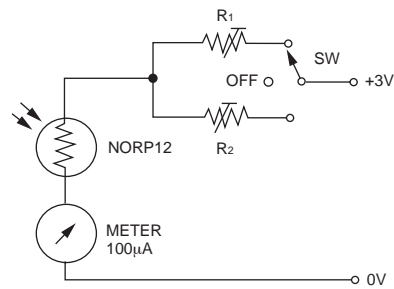

Typical value R¹ = 100kΩ
R² = 200kΩ preset to give two overlapping ranges.
(Calibration should be made against an accurate meter.)

Figure 10 Extremely sensitive light operated relay

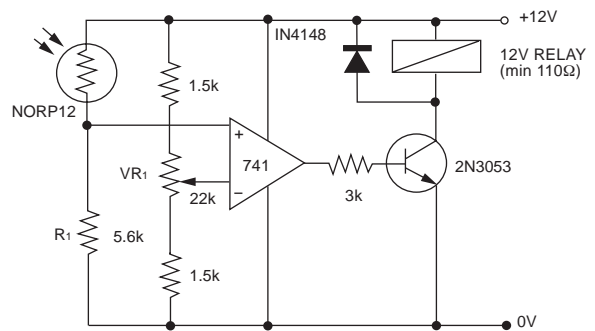

(Relay energised when light exceeds preset level.)
Incorporates a balancing bridge and op-amp. R₁ and NORP12 may be interchanged for the reverse function.