

RoHS compliant

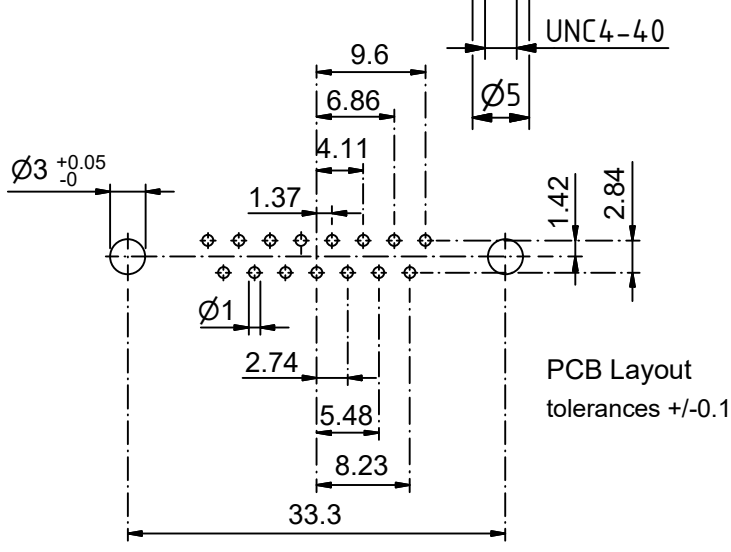
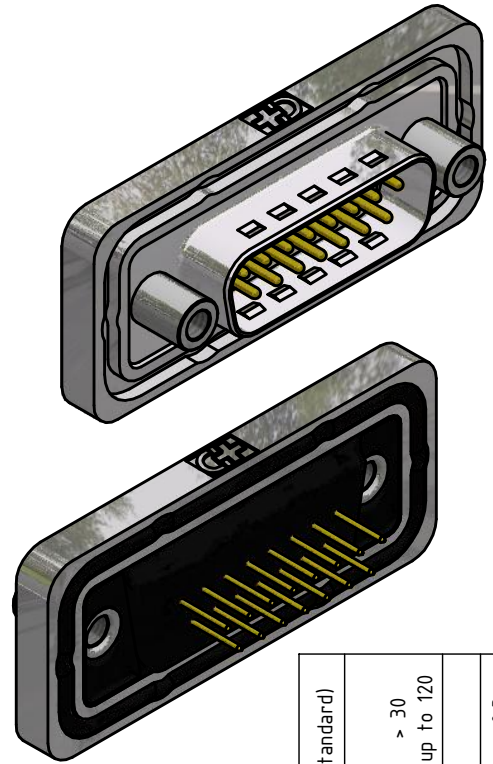
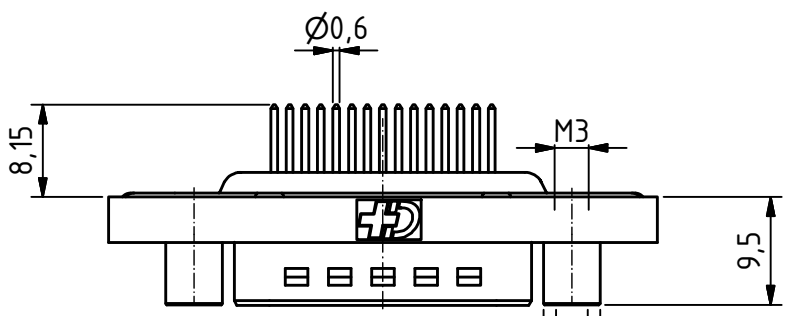
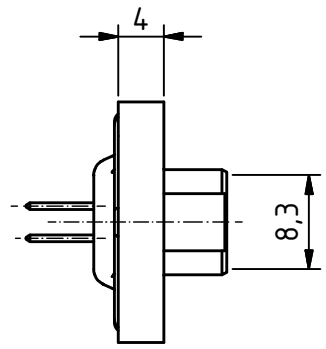
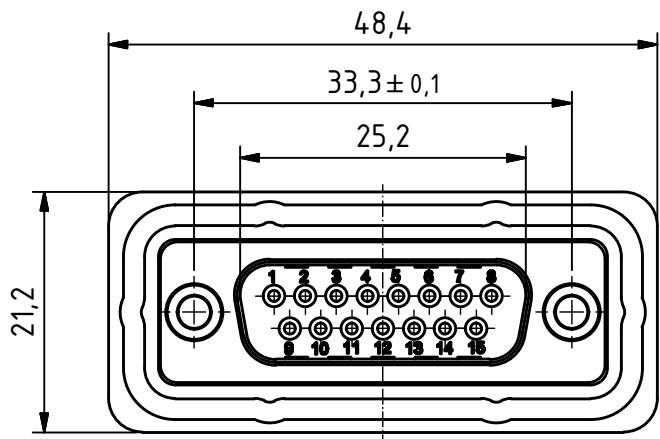

PCB Layout tolerances +/-0.1

Waterproof IP68
Frame with O-ring sealing for front panel mounting

MATERIALS

- Insulator: Thermoplastic UL 94-V-0 white
- Frame: Zinc diecasting nickel plated
- Contact: Machined / Copper alloy
- Contact finish: Quality class 2
- Shell: steel tin plated

CHARAKTERISTICS

- Working voltage: 125V
- Current rating: 7.5A
- Contact resistance: max. 10mΩ - DIN41652
- Insulation resistance: >5GΩ
- Temperature range: -55° to +125°C

Product is suitable for Wave Solder Process

General tolerances (Deltron standard)	
size in mm	
> 0.5 up to 3	±0.1
> 3 up to 6	±0.2
> 6 up to 30	±0.2
> 30 up to 120	±0.3
tolerances	
	±0.1
	±0.2
	±0.3

	All dimensions in mm	Rev.	Rev.	Rev.	DE017210		
		Rev.	Rev.	Rev.	part no.		
DTSWM15PY/2M95UN				1.5:1 scale	drawn	26.02.2016	mw
					checked		
				approved			
				Industrie Neuhof 8c CH-3422 Kirchberg www.d-sub.swiss		K062462	
						drawing no.	