

RoHS compliant

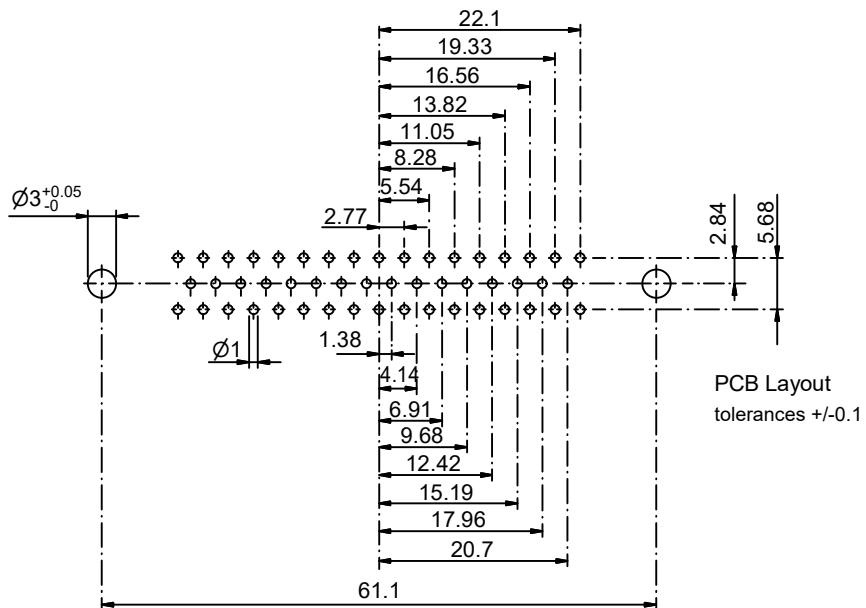
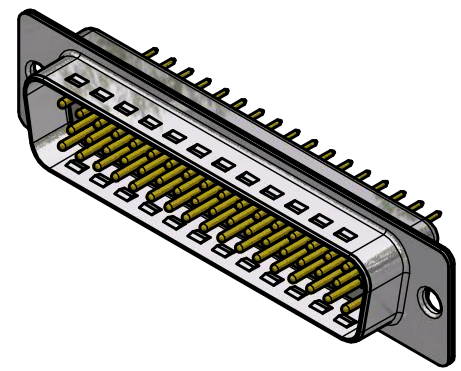
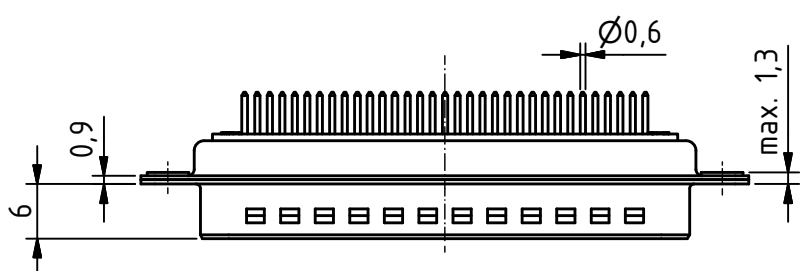
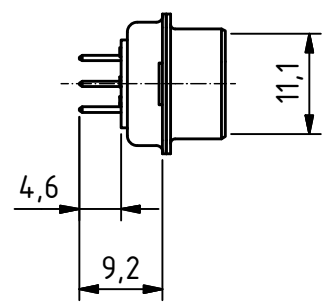
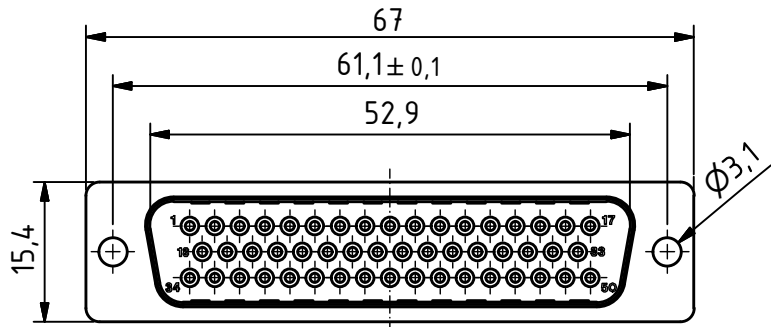

Product is suitable for Wave Solder Process

MATERIALS

- Insulator: Thermoplastic UL 94-V-0 white
- Contact: Machined / Copper alloy
- Contact finish: Quality class 2
- Shell: steel tin plated

CHARAKTERISTICS

- Working voltage: 125V
- Current rating: 7.5A
- Contact resistance: max. 10mΩ - DIN41652
- Insulation resistance: >5GΩ
- Temperature range: -55° to +125°C

General tolerances (Deltron standard)			
size in mm			
> 0.5	> 3	> 6	> 30
up to 3	up to 6	up to 30	up to 120
tolerances			
±0.1	±0.2	±0.2	±0.3

	All dimensions in mm	Rev.	Rev.	Rev.	DE004284		
		Rev.	Rev.	Rev.	part no.		
DTS50PY/2				1.2:1	drawn	05.06.2012	mr
					checked		
				scale	approved		
					K060865		
Industrie Neuhof 8c CH-3422 Kirchberg www.d-sub.swiss					drawing no.		