

RoHS compliant

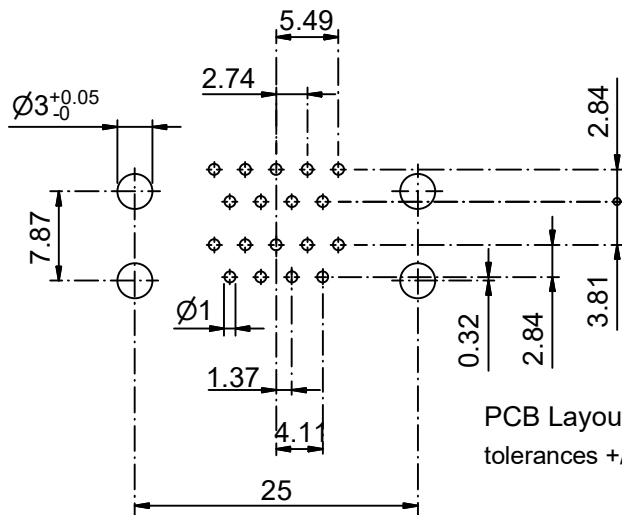
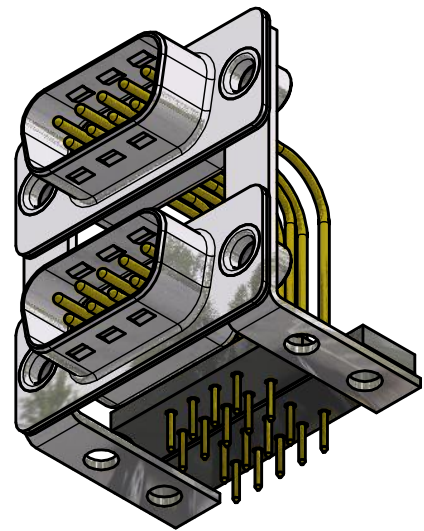
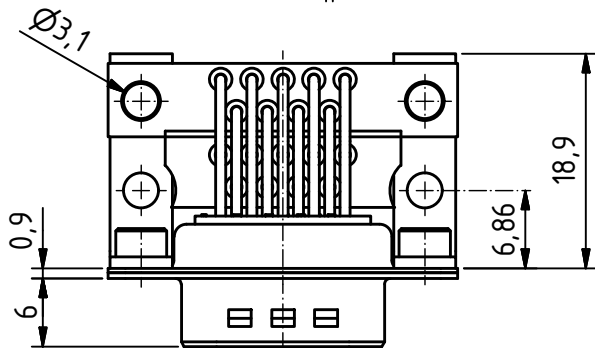
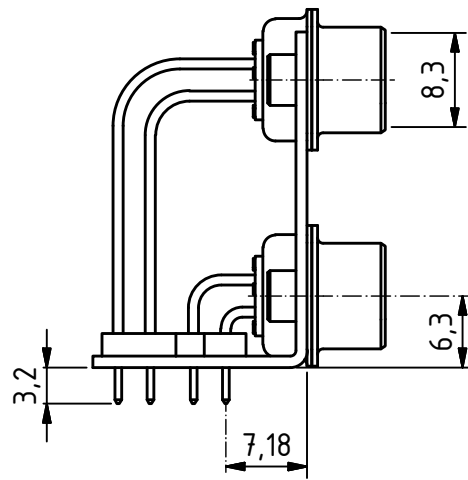
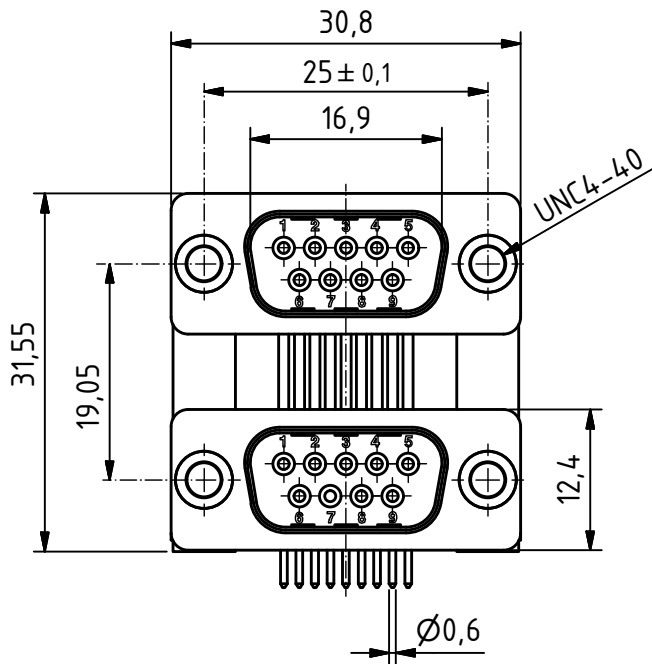

PCB Layout  
tolerances +/-0.1

Product is  
suitable for  
Wave Solder  
Process

**MATERIALS**

- Insulator: Thermoplastic UL 94-V-0 white
- Contact: Machined / Copper alloy
- Contact finish: Quality class 2
- Shell: steel tin plated

**CHARAKTERISTICS**

- Working voltage: 125V
- Current rating: 5A
- Contact resistance: max. 10mΩ - DIN41652
- Insulation resistance: >5GΩ
- Temperature range: -55° to +125°C

General tolerances (Deltron standard)	
size in mm	
> 0,5	> 30
up to 3	up to 30
up to 6	up to 6
up to 30	up to 30
up to 120	up to 120
tolerances	
±0.1	±0.2
±0.2	±0.3

	All dimensions in mm	Rev.	Rev.	Rev.	DE002649		
		Rev.	Rev.	Rev.	part no.		
DPB09PN70/09PN70-S/2				1.5:1	drawn	05.07.2010	mr
				scale	checked		
					approved		
				Industrie Neuhof 8c CH-3422 Kirchberg www.d-sub.swiss		K050701	
						drawing no.	