

CUSTOMER		PART NO:	ETD29
DATE	2012-03-27	TEMPERATURE	25°C
HUMIDITY	48%		

1. DIMENSIONS

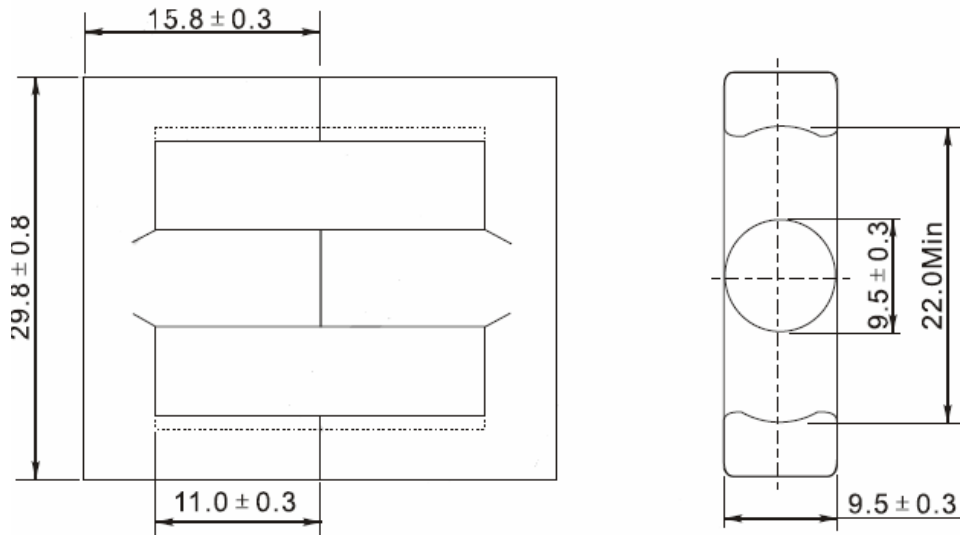

2. ELECTRICAL CHARACTERISTICS

AL nH/N ²	C1 mm ⁻¹	le mm	Ae mm ²	Ve mm ²
2400±25%	0.927	70.7	76.2	5390
TEST Conditions	AL: F=1.0KHz U=0.3V T=25°C ±3°C N=20Ts Pg: F=100KHz B=200mT T=100°C N=100Ts			
TESTING EQUIPMENT	HP4284A CH-258			

PRPARED BY		APPROVED BY	
------------	--	-------------	--



Luženice 10, 344 01 Domažlice
T: 379 723 915, info@atd-elektronik.cz