

RoHS compliant

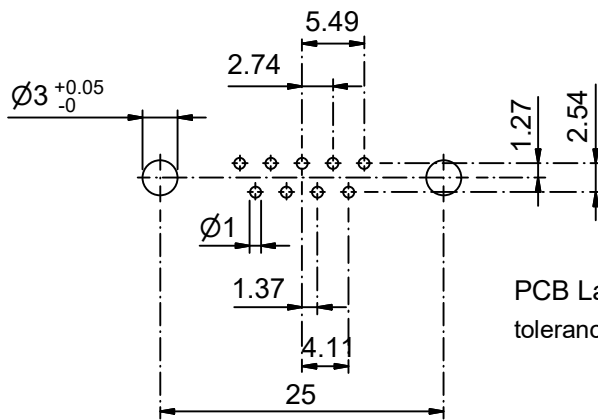
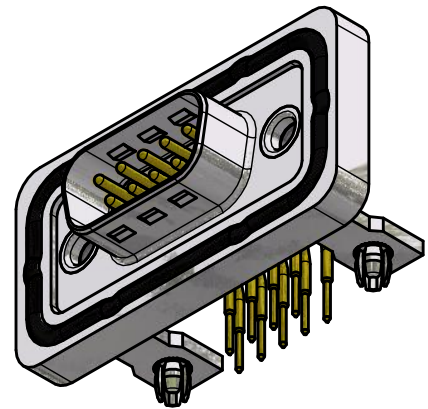
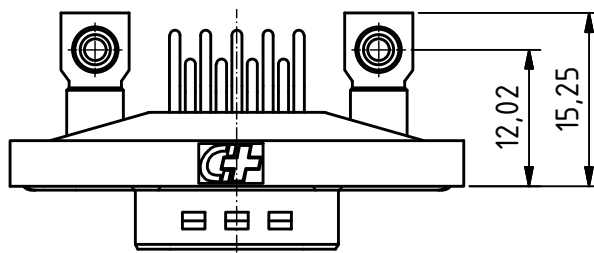
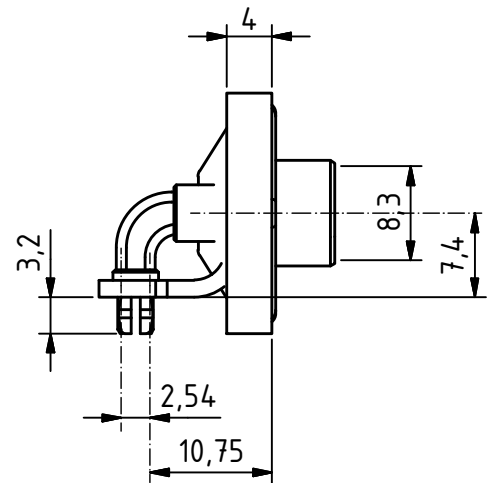
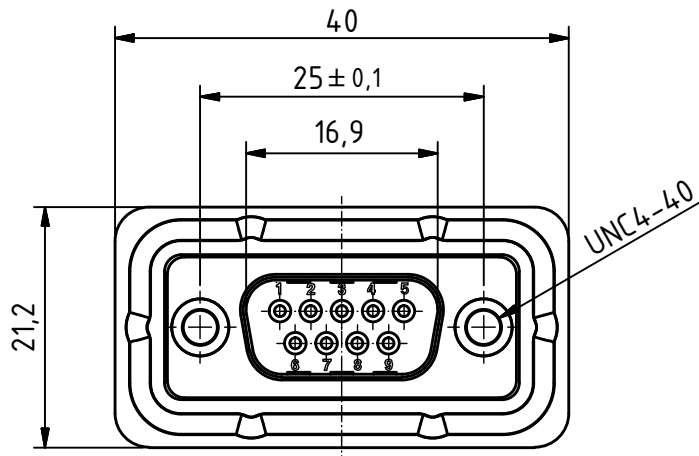

PCB Layout tolerances +/-0.1

Waterproof IP68
Frame with O-ring sealing for back panel mounting

MATERIALS

- Insulator: Thermoplastic UL 94-V-0 white
- Frame: Zinc diecasting nickel plated
- Contact: Machined / Copper alloy
- Contact finish: Quality class 2
- Shell: steel tin plated

CHARAKTERISTICS

- Working voltage: 125V
- Current rating: 7.5A
- Contact resistance: max. 10mΩ - DIN41652
- Insulation resistance: >5GΩ
- Temperature range: -55° to +125°C

Product is suitable for Wave Solder Process

General tolerances (Delttron standard)	
size in mm	tolerances
> 0.5	±0.1
up to 3	±0.2
> 3	±0.2
up to 6	±0.2
> 6	±0.2
up to 30	±0.2
> 30	±0.3
up to 120	±0.3

	All dimensions in mm	Rev.	Rev.	Rev.	DE016966		
		Rev.	Rev.	Rev.	part no.		
DTSWM09PYC/2M4 7UN				1.5:1	drawn	11.09.2015	mr
				scale	checked		
					approved		
				Industrie Neuhof 8c CH-3422 Kirchberg www.d-sub.swiss		K062085 drawing no.	