

RoHS compliant

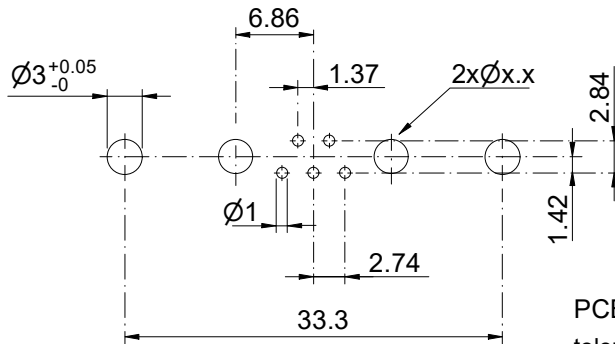

PCB Layout
tolerances +/-0.1

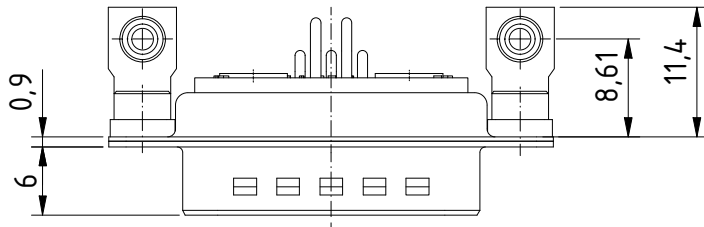
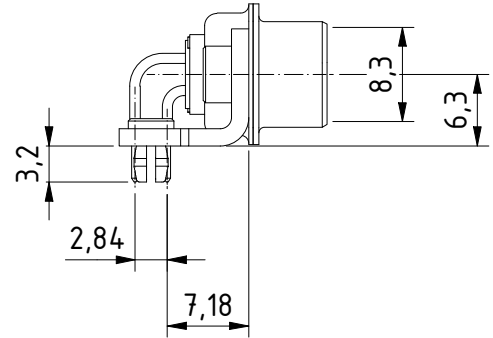
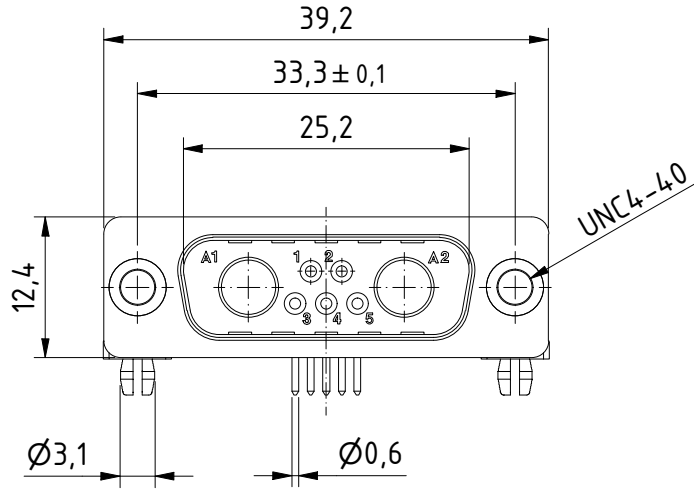
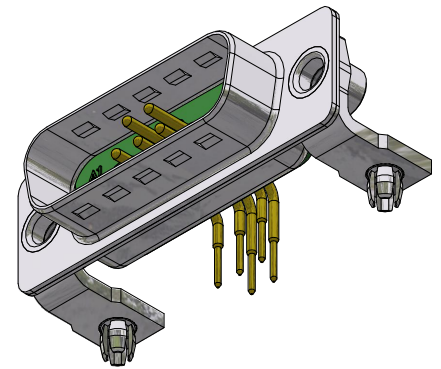

MATERIALS

- Insulator: Thermoplastic UL 94-V-0 green
- Contact: Machined / Copper alloy
- Contact finish: Quality class 2
- Shell: steel tin plated

CHARACTERISTICS

- Working voltage: 125V
- Current rating: 7.5A/xxA
- Contact resistance: max. 10mΩ - DIN14652
- Insulation resistance: >5GΩ
- Temperature range: -55°C to +125°C

Product is
suitable for
Wave Solder
Process

General tolerances (Deltron standard)		tolerances	
size in mm			
> 0.5 up to 3	> 3 up to 6	> 6 up to 30	> 30 up to 120
±0.1	±0.2	±0.2	±0.3

	All dimensions in mm	Rev.	Rev.	Rev.	DExxxxxx part no.
		Rev.	Rev.	Rev.	
DTS7W2PYCA/2M47AUN				1.5:1 scale	drawn 03.02.2022 rop checked approved
				Industrie Neuhof 8c CH-3422 Kirchberg www.d-sub.swiss	K065008 drawing no.