

RoHS compliant

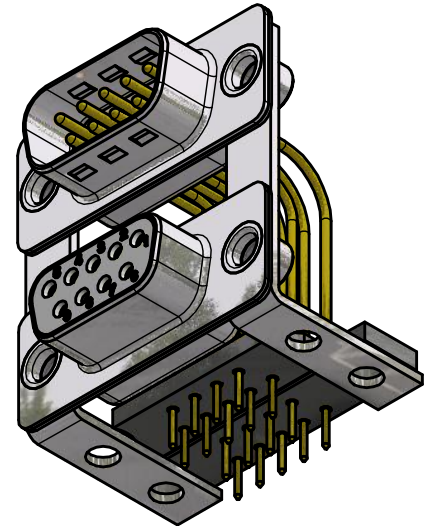
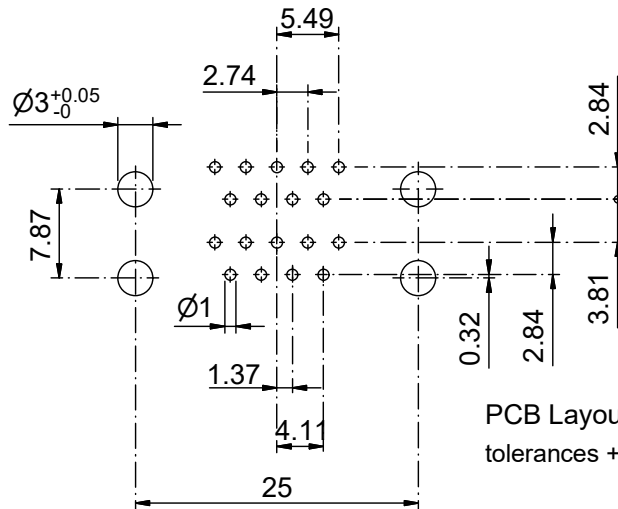
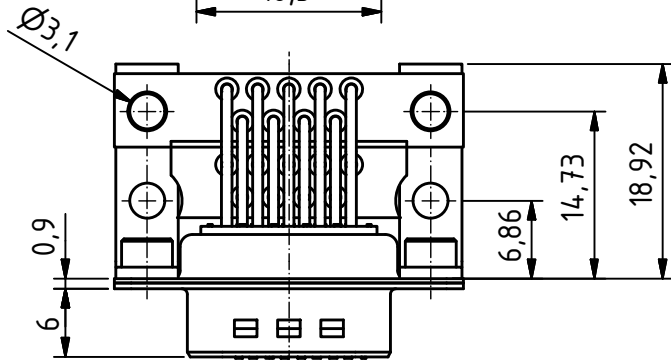
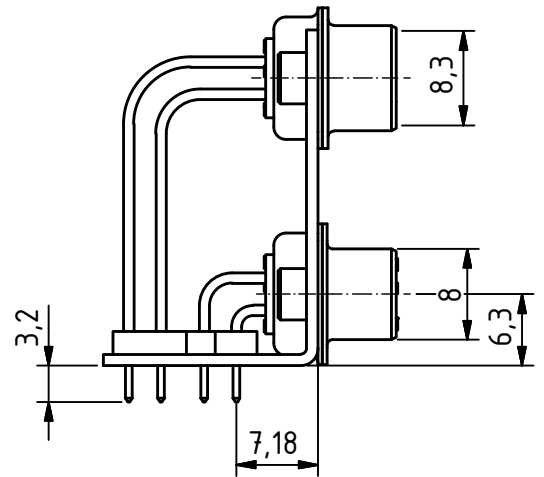

**MATERIALS**

- Insulator: Thermoplastic UL 94-V-0 white
- Contact: Machined / Copper alloy
- Contact finish: Quality class 2
- Shell: steel tin plated

**CHARAKTERISTICS**

- Working voltage: 125V
- Current rating: 5A
- Contact resistance: max. 10mΩ - DIN41652
- Insulation resistance: >5GΩ
- Temperature range: -55° to +125°C

Product is suitable for Wave Solder Process

General tolerances (Deltron standard)	
size in mm	tolerances
> 0.5 up to 3	±0.1
> 3 up to 6	±0.2
> 6 up to 30	±0.2
> 30 up to 120	±0.3

	All dimensions in mm	Rev.	Rev.	Rev.	DE002645		
		Rev.	Rev.	Rev.	part no.		
DPB09PN70/09SN70-S/2				1.5:1	drawn	17.11.2015	mw
				scale	checked		
					approved		
				Industrie Neuhof 8c CH-3422 Kirchberg www.d-sub.swiss		K062340	
						drawing no.	