

HC49US

Features:

- Wide frequency range
- Low cost to performance
- Excellent for clock frequency generation
- Very low profile available

Specifications				
		Symbol	HC49US	Remarks
Frequency range		f	3.2MHz ~ 40.000MHz	Fundamental mode
			30.000MHz ~ 90.000MHz	Overtone mode
Frequency tolerance, Ta=25°C		Δf/f	±3ppm ~ ±50ppm	Please specify
Load capacitance		C <sub>L</sub>	5pF ~ 50pF or series	Please specify
Temperature tolerance		Δf/f	±3ppm ~ ±50ppm	Please specify
Temperature range	Storage temp.	T <sub>STG</sub>	-40°C ~ +105°C	
	Operating temp.	T <sub>OPR</sub>	0°C ~ +70°C / -40°C ~ +105°C	Others are offered
Drive level	Maximum drive level	M <sub>DL</sub>	1000μW	
	Recommended drive level	R <sub>DL</sub>	10μW ~ 100μW	
Series resistance		R <sub>1</sub>	As per table	25°C ±3°C
Shunt capacitance		C <sub>0</sub>	7pF	Max
Insulation resistance		I <sub>R</sub>	500M Ohm	Min
Aging		Δf <sub>A</sub>	±5ppm/Year max	Others are offered

Resistance of series resonance (ESR)					
Frequency (MHz)	Mode	Ohm max	Frequency (MHz)	Mode	Ohm max
3.570 ≤ f < 3.999	Fundamental	140	8.000 ≤ f < 9.999	Fundamental	70
4.000 ≤ f < 4.999	Fundamental	110	10.000 ≤ f < 14.999	Fundamental	50
5.000 ≤ f < 5.999	Fundamental	90	15.000 ≤ f < 35.000	Fundamental	35
6.000 ≤ f < 7.999	Fundamental	80	30.000 ≤ f < 90.000	3rd OT	70

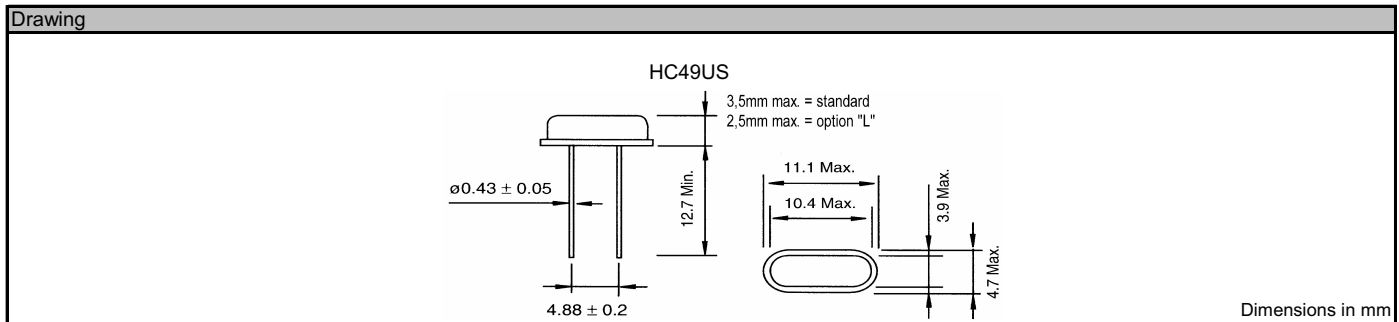

Order key								
Q	- 10.000000M	- HC49US	- F	- 30	- 50	- D	- 30	- I
Part	Frequency	Package	Mode of oscillation	Frequency tolerance	Temperature tolerance	Temperature range	Load capacitance	Option
Q=Quartz	M=MHz	HC49US	F=fund. 3=3. OT	±ppm (25° C)	±ppm (Temp. range)	A= 0° C ~ 70° C B= - 10° C ~ 60° C C= - 10° C ~ 70° C D= - 20° C ~ 70° C E= - 40° C ~ 85° C F= - 40° C ~ 105° C H= - 20° C ~ +80° C I= - 10° C ~ +50° C	pF SR=series	3P=3P in version L=Low height TA=Taped am mopack I=Insulation washers X=Special options

Remarks: All specifications subject to change without notice!